

Bi2 WALL TR

1000-1200-1400

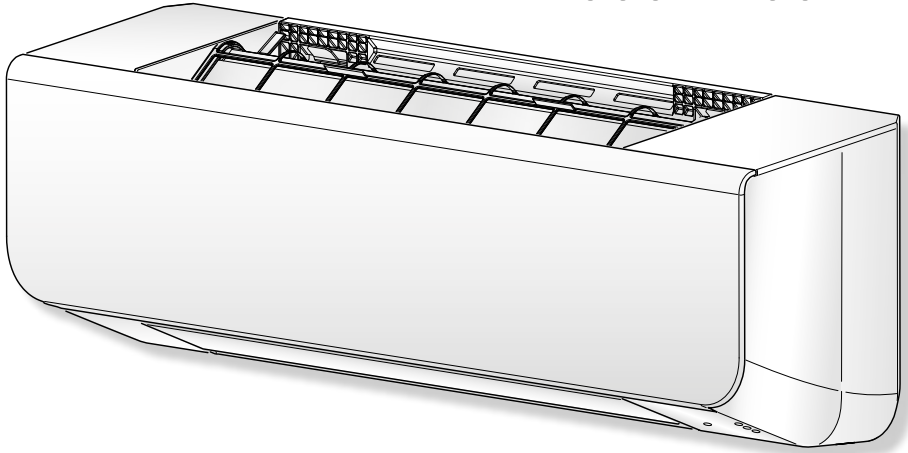

INSTRUCTION FOR USE AND MAINTENANCE **EN**

1. This appliance can be used by children aged from 8 years and above and person with reduced physical, sensory or mental capabilities or lack of experience and knowledge if they have been given supervision or instruction concerning use of the appliance in a safe way and understand the hazards involved. Children shall not play with the appliance. Cleaning and user maintenance shall not be made by children without supervision (be applicable for the European Countries).
2. This appliance is not intended for use by persons (including children) with reduced physical, sensory or mental capabilities or lack of experience and knowledge, unless they have been given supervision or instruction concerning use of the appliance by a person responsible for their safety. (be applicable for other countries except the European Countries).
3. If the power cable is damaged, it must be replaced by the manufacturer or by its technical support service or by similarly qualified personnel, to prevent any risk to the user.
4. To prevent the risk of electrocution, it is essential to disconnect the power supply before performing all maintenance operations on the appliance.
5. For the correct operation of the appliance, observe the minimum distances and the indications written in this manual.



0 - GENERAL INFORMATION	3
0.1 - SYMBOLS	3
0.2 - EDITORIAL PICTOGRAMS	3
0.3 - GENERAL WARNINGS	4
0.4 - IMPORTANT SAFETY INFORMATION	5
0.5 - INSTALLATION INFORMATION	10
0.6 - HAZARDOUS ZONES	10
0.7 - PROPER USE	10
1 - DESCRIPTION OF THE APPLIANCE	11
1.1 - IDENTIFICATION OF THE MAIN COMPONENTS (Fig.1)	11
1.2 - DESCRIPTION OF THE APPLIANCE (Fig.2)	12
1.3 - OVERALL DIMENSIONS (Fig.3)	12
2 - INSTALLATION SEQUENCE	12
3 - INSTALLATION	13
3.1 - INSPECTING AND HANDLING THE UNIT	13
3.2 - INSTALLATION OF THE APPLIANCE	13
3.2.1 - Place of installation	13
3.2.2 - Water hoses and condensation drain positioning	14
3.2.3 - Assembly of the fixing plate	15
3.2.4 - Appliance shell disassembly	16
3.2.5 - Appliance fixing	17
4 - HYDRAULIC CONNECTION	18
4.1 - LOAD LOSSES GRAPH	19
5 - ELECTRICAL CONNECTION	20
5.1 - CONFIGURATION	22
5.1.1 - Presence contact input	22
5.1.2 - Hot/cold generator switching on consent contact	23
5.2 - CONNECTION WITH WIRED REMOTE CONTROL B0736 OR THIRD PARTIES MODBUS	23
5.3 - CONNECTION WITH SIOS CONTROL	23
5.4 - BOARD SOFTWARE CONFIGURATION	24
6 - OPERATING CONDITIONS	26
7 - USE OF THE APPLIANCE	27
7.1 - SYMBOLS AND KEYS OF THE CONTROL PANEL (Fig.16)	27
7.2 - REMOTE CONTROL DISPLAY (Fig.17)	27
7.3 - REMOTE CONTROL KEYS (Fig.18)	28
7.4 - USE OF THE REMOTE CONTROL	28
7.4.1 - Insertion of batteries	29
7.4.2 - Replacement of batteries	29
7.4.3 - Location of the remote controller	30
7.5 - APPLIANCE SWITCHING ON/OFF	30
7.6 - AUTOMATIC COOLING /HEATING MODE	30
7.7 - MANUAL COOLING/ HEATING MODE	31
7.8 - FAN MODE	31
7.8.1 - Operation at maximum speed	32
7.8.2 - Operation at AUTO speed	32
7.9 - NIGHT OPERATION	32





7.10 - MEANING OF BLINKING AND OPERATION OF THE LED	33
7.11 - SWING OPERATION	33
7.12 - SPECIAL FUNCTIONS	34
7.12.1 - Air sampling	34
7.12.2 - Commands lock	34
7.12.3 - Water not suitable	34
7.12.4 - Water probe inhibition	35
7.13 - OPERATION WITH TIMER (delayed switching on and switching off)	35
7.13.1 - Setting of the switching on timer from remote controller	35
7.13.2 - Setting of the switching off timer from remote controller	35
7.14 - SWITCHING OFF FOR PROLONGED PERIODS	36
7.15 - ALARMS KEY	36
8 - MAINTENANCE AND CLEANING	36
8.1 - CLEANING	37
8.1.1 - Cleaning the appliance and the remote control	37
8.1.2 - Cleaning the air filter	37
8.2 - MAINTENANCE	38
9 - TROUBLESHOOTING	38
9.1 - SYMPTOMS THAT DO NOT INDICATE APPLIANCE MALFUNCTIONING	38
9.2 - INCONVENIENCES AND POSSIBLE REMEDIES	39

TECHNICAL DATA

For the data of the energy consumptions, please refer to the unit technical characteristics plate.

Models		1000	1200	1400
Description				
Battery water content	l	0,75	0,97	0,97
Maximum operating pressure	bar	10	10	10
Water delivery maximum temperature	°C	70	70	70
Water delivery minimum temperature	°C	3	3	3
Water connections	-	1/2	1/2	1/2
Power voltage	V- ph Hz	230 -1 50	230 -1 50	230 -1 50



DISPOSAL

This symbol on the product or its packaging indicates that the appliance cannot be treated as normal domestic trash, but must be handed in at a collection point for recycling electric and electronic appliances. Your contribution to the correct disposal of this product protects the environment and the health of your fellow men. Health and the environment are endangered by incorrect disposal. Further information about the recycling of this product can be obtained from your local town hall, your refuse collection service, or in the store at which you bought the product. This regulation is valid only in EU member states.



0 - GENERAL INFORMATION

First of all, we would like to thank you for choosing our appliance.

This document is confidential pursuant to the law and may not be reproduced or transferred to third parties without the explicit authorisation of the manufacturer. The appliance may undergo updates and therefore have details different from those represented, without prejudice to the texts contained in this manual.

0.1 - SYMBOLS

The pictograms in the next chapter provide the necessary information for correct, safe use of the machine in a rapid, unmistakable way.

0.2 - EDITORIAL PICTOGRAMS



DANGER OF HIGH VOLTAGE

Signals to the personnel that the operation described could cause electrocution if not performed according to the safety rules.



DANGER

Indicates that the appliance uses flammable refrigerant. If the refrigerant leaks and is exposed to an external ignition source, the risk of fire exist.



GENERIC DANGER

It informs the personnel concerned that if the operation is not carried out in compliance with the safety regulations, it presents the risk of suffering physical damage.



DANGER DUE TO HEAT CALORE

It informs the personnel concerned that if the operation is not carried out in compliance with the safety regulations, it presents the risk of burns due to contact with components at very high temperatures.



DO NOT COVER

Indicates to the personnel concerned, that it is prohibited to cover the appliance, to prevent over-heating.



WARNING

- Indicates that this document must be read carefully before installing and/or using the appliance.
- Indicates that this document must be read carefully before any maintenance and/or cleaning operation.





- Indicates that the assistance personnel must handle the appliance following the installation manual.



Service

Marks situations in which the information must reach the:

CUSTOMER TECHNICAL SERVICE



Index

Paragraphs marked with this symbol contain very important information and recommendations, particularly as regards safety.

Failure to comply with them may result in:

- danger of injury to the operators
- loss of the warranty
- refusal of liability by the manufacturer.



Raised hand

Refers to actions that absolutely must not be performed.

0.3 - GENERAL WARNINGS

WHEN USING ELECTRICAL EQUIPMENT, BASIC SAFETY PRECAUTIONS MUST ALWAYS BE FOLLOWED IN ORDER TO REDUCE RISKS OF FIRE, ELECTRIC SHOCKS AND INJURY, INCLUDING THE FOLLOWING:

1. Read this manual carefully before performing any operation (installation, maintenance, use) and follow the instructions contained in each chapter
2. Make all personnel involved in transport and installation of the machine aware of these instructions.
3. The manufacturer is not responsible for damages to persons or property caused by failure to follow the instructions in this manual.
4. The manufacturer reserves the right to make any changes it deems advisable to its models, although the essential features described in this manual remain the same.
5. Keep the manual carefully for future reference.
6. Failing to comply with the instructions contained in this manual, and using the unit with temperatures exceeding the permissible temperature range will invalidate the warranty.
7. Routine maintenance of the filters and general external cleaning can be done by the user as these operations are not difficult or dangerous.
8. During assembly and at each maintenance operation, it is necessary to respect the



precautions indicated in this manual and on the labels located inside or on the appliance, as well as to take all the precautions suggested by common sense and by the

Safety Regulations in force in the country of installation.

0.4 - IMPORTANT SAFETY INFORMATION

The safety precautions listed are divided into two categories. In either case, important safety information is listed which must be read carefully.



WARNING

Failure to observe a warning may result in death.



WARNING

Failure to observe a caution may result in injury or damage to the equipment.



WARNING

1. Be sure only trained and qualified service personnel to install, repair or service the equipment.
2. Improper installation, repair, and maintenance may result in electric shocks, short-circuit, leaks, fire or other damage to the equipment.
3. Install according to this installation instructions strictly.
If installation is defective, it will cause water leakage, electrical shock and fire.
4. Use the attached accessories parts and specified parts for installation.
Otherwise, it will cause the set to fall, water leakage, electrical shock and fire.
5. The unit must be installed at a minimum height of 2,21 m from the floor.
6. The appliance shall not be installed in the laundry.
7. Before obtaining access to terminals, all supply circuits must be disconnected.
8. The hydraulic connections of the appliance must indicate, with words or symbols, the liquids direction of circulation.
9. For electrical work, follow the local national wiring standard, regulation and this installation instructions. An independent circuit and single outlet must be used.
If electrical circuit capacity is not enough or defect in electrical work,



- it will cause electrical shock fire.
10. Use the specified cable and connect tightly and clamp the cable so that no external force will be acted on the terminal.
If connection or fixing is not perfect, it will cause heat-up or fire at the connection.
 11. Wiring routing must be properly arranged so that control board cover is fixed properly.
If control board cover is not fixed perfectly, it will cause heat-up at connection point of terminal, fire or electrical shock.
 12. If the supply cord is damaged, it must be replaced by the manufacture or its service agent or a similarly qualified person in order to avoid a hazard.
 13. An all-pole disconnection switch having a contact separation of at least 3mm in all poles should be connected in fixed wiring.
 14. The cold water temperature inside the unit must not be lower than 3°C, while hot water must not exceed 70°C. Water in the unit must clean, air quality must meet to the standard of PH=6. 5 and 7. 5.
 15. Do not disconnect the electric power supply manually when the appliance is running, since malfunctioning could occur.
 16. Ask your dealer for installation of the air conditioner.
Incomplete installation performed by yourself may result in a water leakage, electric shock, and fire.
 17. Ask your dealer for improvement, repair, and maintenance.
Incomplete improvement, repair, and maintenance may result in a water leakage, electric shock, and fire.
 18. In the event of operating anomalies (e.g. strange noise, bad odour, smoke, abnormal temperature rise, electric dispersions, etc.), switch the appliance off immediately and disconnect the electric power supply. For repair work contact solely the technical service centres authorised by the manufacturer and ask for original spare parts to be used. Failure to do this can affect the safety of the appliance.
 19. Do not wet the indoor unit and the remote control.
Short circuits or fires may occur.
 20. If a fuse blows, do not replace it with one that has a different amperage and do not use cables of any type.
Use of wire or copper wire may cause the unit to break down or cause a fire.
 21. It is not good for your health to expose your body to the air flow for a long time.
 22. Do not insert fingers, bars or other objects inside the air input and output grilles. When the fan is rotating at high speed, it will cause



- injury.
23. Never use a flammable spray such as hair spray, lacquer or paint near the unit. It may cause a fire.
 24. Do not touch the horizontal air outlet flaps when the swing function is active. Fingers may become caught or the unit may break down.
 25. Do not obstruct the air inlet and outlet grids in any manner.
 26. Do not insert extraneous items in the air inlet and outlet grids as this will create the risk of electrical shocks, fire or damages to the appliance.
Objects touching the fan at high speed can be dangerous.
 27. Do not inspect the unit or perform maintenance personally. Repairing the appliance yourself is extremely dangerous. Contact a qualified professional.
 28. Do not dispose this product as unsorted municipal waste. Collection of such waste separately for special treatment is necessary.
 29. The most common cause of overheating is dust or lint deposit in the appliance. Regularly remove these accumulations by disconnecting the appliance from the power socket and vacuuming the grids.
 30. In the event that you decide not to use an appliance of this type anymore, it is recommended to make those parts of the appliance susceptible to constitute a danger harmless, especially for children which may use the out-of-order appliance for their own games.



CAUTION

1. Before installing the unit, it is necessary to check whether the ground wire is charged.
If it is, the unit shall not be installed before correction.
2. Ground the air conditioner.
Do not connect the ground wire to gas or water pipes, lightning rod or a telephone ground wire. Incomplete grounding may result in electric shocks.
3. Be sure to install an earth leakage breaker.
Failure to install an earth leakage breaker may result in electric shocks.
4. It is not allowed to connect the appliance to the power supply before the electric wiring and hydraulic connection have been performed.
5. While following the instructions in this installation manual, install drain piping in order to ensure proper drainage and insulate piping in order to prevent condensation.
Improper drain piping may result in water leakage and property damage.



6. Install the appliance, the power supply cables and connection cables at a distance of at least 1 metre from television and radio appliances in order to prevent interference on the images or noise. Depending on the length of the radio waves, 1 metre may be insufficient to eliminate noise.
7. Don't install the air conditioner in the following locations:
 - There is caustic gas (the sulfide, for example) existing in the air (near a hot spring)
 - The Volt vibrates violently (in the factories)
 - In kitchen where it is full of oil gas
 - There is strong electromagnetic wave existing
 - There are inflammable materials or gas
 - There is acid or alkaline liquid evaporating
 - Other special conditions.
8. Do not use the appliance for purposes different than the declared use. To prevent deterioration of the quality, do not use the unit to cool precision tools, foodstuffs, plants, animals or works of art.
9. Before cleaning, be sure to stop the operation, turn the breaker off or pull out the supply cord, otherwise, an electric shock and injury may result.
10. Be sure the air conditioner is grounded.
11. In order to avoid electric shock, make sure that the unit is grounded and that the earth wire is not connected to gas or water pipe, lightning conductor or telephone earth wire.
12. Do not operate the air conditioner with a wet hand. An electric shock may happen.
13. Do not touch the heat exchanger fins. These fins are sharp and could result in cutting injuries.
14. Do not position objects, which could be damaged by humidity, under the appliance. Condensate can form if the level of humidity exceeds 80%; the drain outlet is blocked or the filter is dirty.
15. After a long use, check the unit stand and fitting for damage. If damaged, the unit may fall and result in injury.
16. To prevent the lack of oxygen, ventilate the environment adequately if the appliance is used along with appliances fitted with burner.
17. Organise the drain pipe in a way to ensure regular condensate draining. Incomplete drainage can cause damage to the building, furniture, etc. due to humidity.
18. Do not touch the internal components of the electric box.
Do not remove the front panel. Some parts inside are dangerous to touch, and a machine trouble may happen.



19. Never expose little children, plants or animals directly to the air flow. Adverse influence to little children, animals and plants may result.
20. Do not allow a child to mount on the outdoor unit or avoid placing any object on it.
Falling or tumbling may result in injury.
21. Never press the button of the remote controller with a hard, pointed object.
22. Do not use the appliance if insecticide gas has just been sprayed in the room or in the presence of burning incenses, chemical vapours or oily residues.
23. In case of replacement of parts, use only original parts.
24. If the unit is unused for a long period, or no-one uses the climate-controlled room, it is recommended to disconnect the electric power supply in order to prevent accidents.
25. Do not use liquid or corrosive detergents to clean the unit, do not spray water or other liquids onto the unit, since they could damage the plastic components or even cause electric shocks.
26. Do not allow the appliance to function for long periods if humidity is high and there are doors and windows open.
The humidity could condensate and wet or damage the furnishings.
27. Clean the appliance with a damp cloth; do not use abrasive products or materials. See the appropriate paragraph for the filters cleaning.
28. Do not use the appliance in environments subject to significant temperature changes as condensation could form inside the appliance itself.
29. Do not use the appliance if the filters are not positioned correctly.
30. Do not position equipment that produces naked flames in points exposed to air currents or underneath the appliance.
31. Disassembly, repair or reconversion performed by an unauthorized person could cause heavy damages and will cancel the manufacturer warranty.
32. Do not use the appliance if it breaks or malfunctions, if the electric power supply cable is damaged or if there is any type of damage whatsoever. Switch the appliance off, disconnect the electric power supply and have it checked by qualified professional staff.



0.5 - INSTALLATION INFORMATION

1. To install properly, please read this “installation manual” at first.
2. The air conditioner must be installed by qualified persons.
3. Follow the manual as closely as possible during the installation of the appliance and piping.
4. If the appliance is installed on a metal surface of the building, it must be isolated electrically pursuant to the standards in force regarding electrical equipment.
5. When all the installation work is finished, please turn on the power only after a thorough check.

0.6 - HAZARDOUS ZONES

- The fan coil must not be installed in environments with the presence of inflammable gases, explosive gases, in very humid environments (laundries, greenhouses, etc.), or in places with other machines that generate a strong heat source, in proximity of a sources of salt water or sulphurous water.
- DO NOT use gas, gasoline or other inflammable liquids near to the fan coil.
- Only use supplied components (see paragraph 1.2). The use of non-standard parts may cause water leaks, electric shocks, fires and injuries or damages to things.
- Do not install the appliance in areas characterised by brackish air (near to the coast, etc.).

If electrical appliances are disposed of in landfills or dumps, hazardous substances can leak into the groundwater and get into the food chain, damaging your health and well-being.

0.7 - PROPER USE

- The fan coil must only be used to heat, cool, dehumidify and filter the air (by choice) with the exclusive purpose of making the room temperature comfortable.
- This appliance is only intended for a domestic use or similar  ; not for commercial or industrial use.
- An improper use of the appliance with possible damages caused to people, property or animals relieves the manufacturer from any liability.



- This appliance is not intended to be run via an external timer or with a separate remote control system (use the remote control supplied only).



THIS PRODUCT MUST BE USED EXCLUSIVELY ACCORDING TO THE SPECIFICATIONS INDICATED IN THIS MANUAL. USE DIFFERENT TO THAT SPECIFIED, COULD CAUSE SERIOUS INJURIES.

THE MANUFACTURER IS NOT LIABLE FOR INJURY/DAMAGE TO PERSONS/OBJECTS DERIVING FROM FAILURE TO COMPLY WITH THE REGULATIONS CONTAINED IN THIS MANUAL.

1 - DESCRIPTION OF THE APPLIANCE

1.1 - IDENTIFICATION OF THE MAIN COMPONENTS (Fig.1)

- | | |
|---|--|
| <ol style="list-style-type: none"> 1. Body of appliance 2. Front panel 3. Display 4. Air inlet 5. Air outlet 6. Horizontal air deflector 7. Air filters 8. Filter support frame | <ol style="list-style-type: none"> 9. Use and maintenance manual (+ warranty) 10. Remote control 11. Battery for remote control (not supplied)
quantity 2 - AAA type x 1.5V 12. Terminal box |
|---|--|

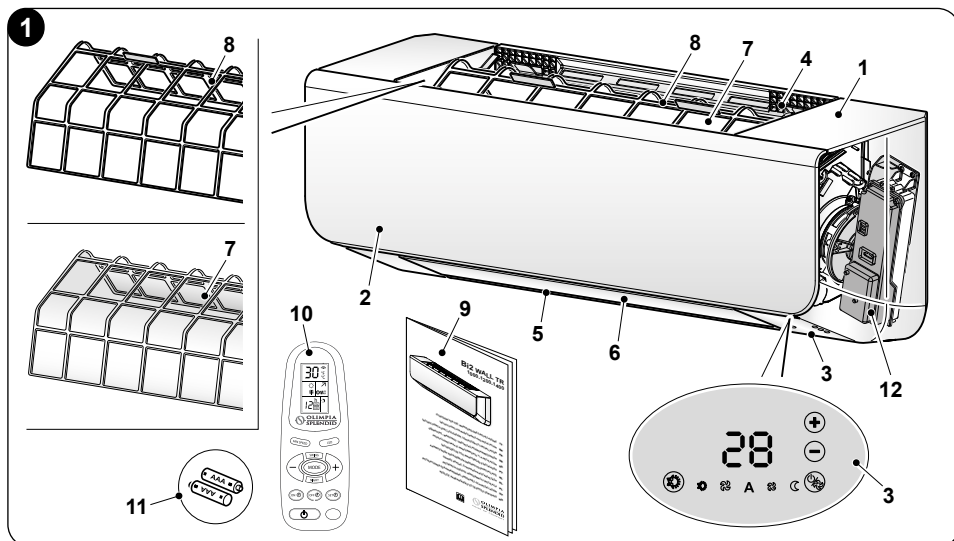

1.2 - DESCRIPTION OF THE APPLIANCE (Fig.2)

Please check whether the following fittings are of full scope.

If there are some spare fittings, please restore them carefully.

- A. Wall fixing plate
- B. Template

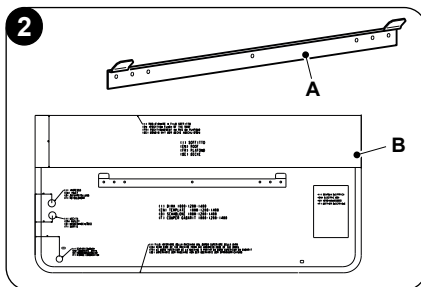

1.3 - OVERALL DIMENSIONS (Fig.3)

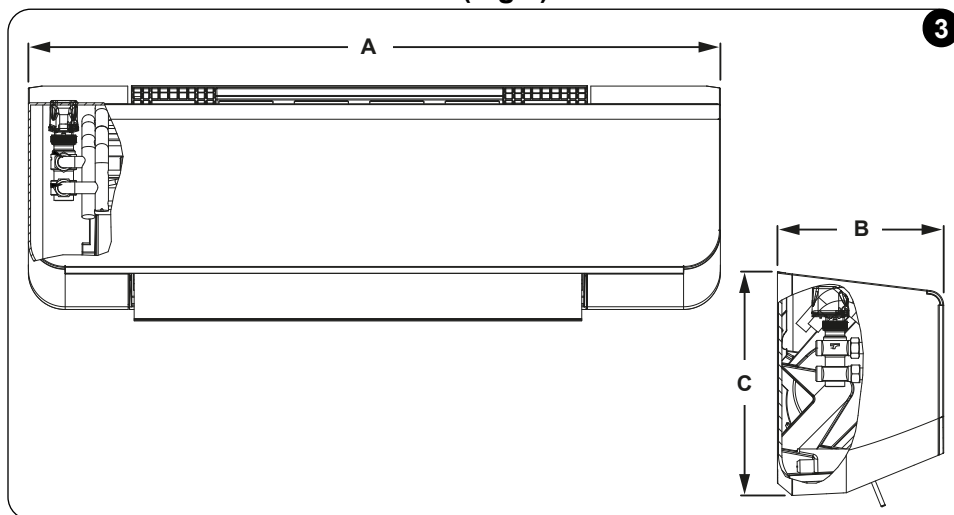

	A (mm)	B (mm)	C (mm)	Weight (kg)
1000	940	226	304	11
1200	940	226	304	12
1400	940	226	304	12

2 - INSTALLATION SEQUENCE

For successful installation of the appliance, perform the operations secon this order:

- a. Choose the place of installation.
- b. Prepare the water pipelines and for condensation drainage using the supplied template.
- c. Use the template to place the bracket on the wall and fix it.
- d. Disassemble the front shell.

>>>>



- e. Hang the appliance on the bracket and fix it to the wall.
- f. Carry out the hydraulic connection and condensation drain.
- g. Carry out the electrical connection and the configuration.
- h. Reassemble the front shell.
- i. Check for correct operation of the appliance.

3 - INSTALLATION

3.1 - INSPECTING AND HANDLING THE UNIT

At delivery, the package should be checked and any damage should be reported immediately to the carrier claims agent. When handling the unit, take into account the following:

- a. **Fragile product, handle with care.**
- b. **Choose the path to be followed for unit transport in advance.**
- c. **Transport the unit by keeping it as long as possible inside its original packaging.**

3.2 - INSTALLATION OF THE APPLIANCE

3.2.1 -Place of installation



Before installation of the unit, check with the user for the possible presence of cables, hydraulic or gas hoses, etc. inside the wall or floor to avoid damages caused by installation.

Avoid installation in the following places to avoid inconveniences:

- Environments with high concentration of oils for machinery.
- Brackish environments, such as coastal areas.
- Environments with high concentration of sulphurous gases, such as spa facilities.
- Places where high frequency machinery is present, such as wireless equipment, welding machinery and medical equipment.
- Environments with the presence of combustible gases and hazardous substances.
- Places with special environmental conditions.
- The environment must not be exposed to strong electro-magnetic waves.
- The place of installation must be distant from sources of heat, steam and inflammable gases.

Before installation, make sure that:

- The area with inlet and outlet connections must be free from obstructions.
- Make sure that curtains or other objects do not obstruct the air suction filters.
- The place of installation must be able to support the indoor unit.
- The place of installation must allow easy maintenance.



- The place of installation must ensure enough space around the unit, as indicated in figure 4.

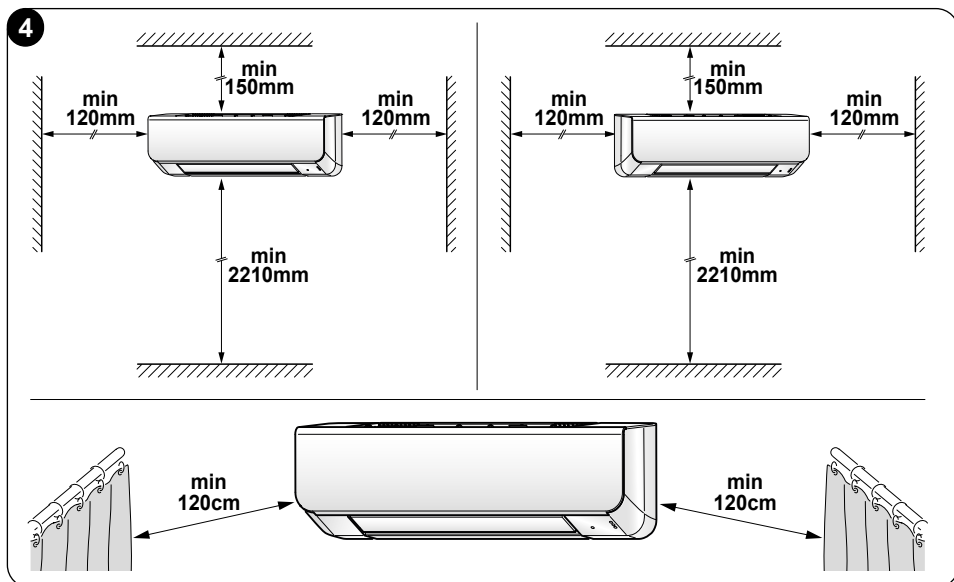

3.2.2 -Water hoses and condensation drain positioning

Using the template (B), determine the point where the condensation drain hose (not supplied) and the water hoses must be positioned.



Check for correct outflow of condensation inside the prepared drain by slowly pouring an appropriate quantity of water inside it.

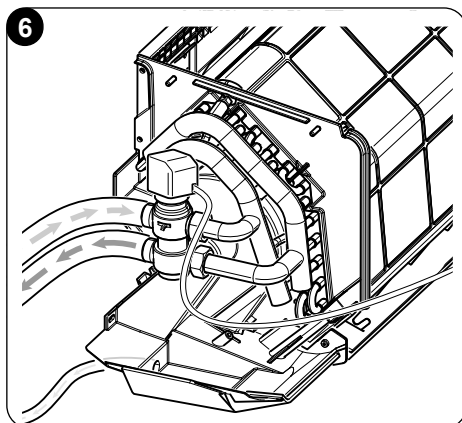
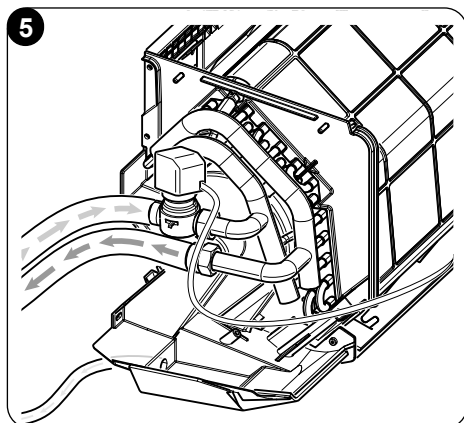

3.2.3 - Assembly of the fixing plate



BEFORE FIXING THE PLATE, MAKE SURE THAT THE WALL WHERE THE APPLIANCE IS TO BE INSTALLED CAN SUPPORT THE WEIGHT.

Operate as follows (fig. 7):

- Place the supplied drilling template (B) against the wall respecting the minimum distances from the roof, from the floor and from the lateral walls; it is advised to keep the template in correct position using adhesive tape (C).
- Mark the drilling points (9 points recommended).



The two holes (F) are prepared for wall fixing of the appliance.

- In the case of brick or concrete walls or similar, make 9 x 5 mm diameter holes.
- Insert the plugs (D) inside the holes (use suitable plugs on the basis of the type of wall).
- Fix the plate (A) to the wall tightening all screws (E).

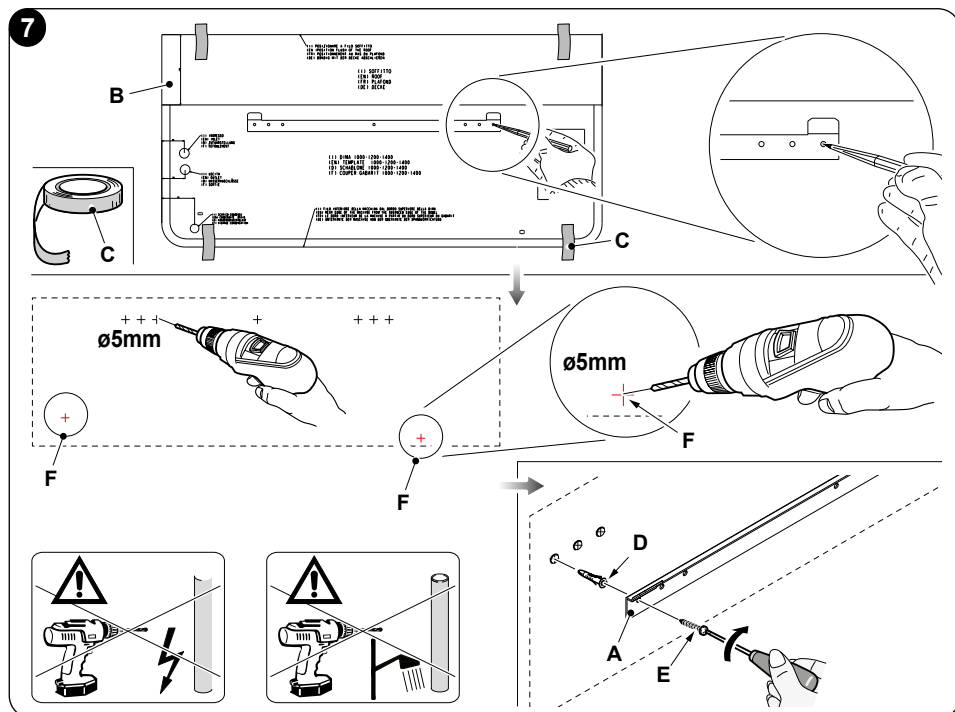

3.2.4 -Appliance shell disassembly

Work as follows (fig. 8-9):

- a. Undo the 4 upper screws (X).
- b. Undo the 2 lower screws (Y).

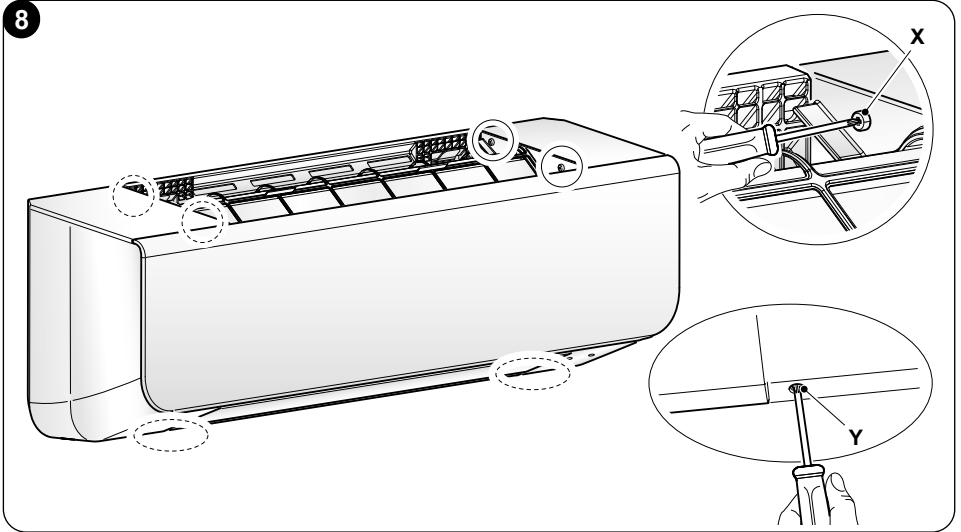

DISCONNECT THE EARTH CABLE AND THE CONNECTION TO THE DISPLAY BEFORE REMOVING THE FRONT SHELL.

- c. Remove the front shell (1a) of the appliance (1) paying attention not to damage it.

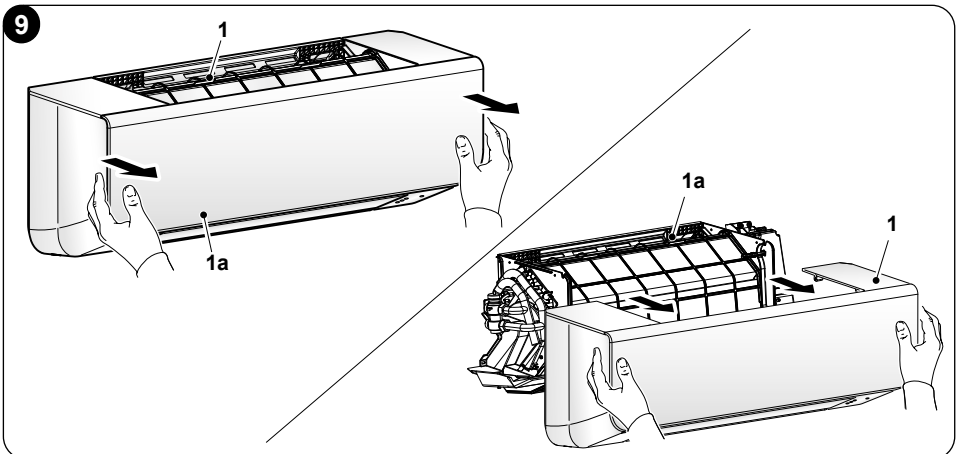

3.2.5 -Appliance fixing

Work as follows (fig. 10):

- a. Insert the bracket (A) on the back of the unit (1) inside the hook (1a) of the installation bracket and move the unit horizontally and vertically to ensure it has been hooked firmly.
- b. Push the lower part of the Indoor Unit up to the wall, Then move the Indoor Unit from side to side, up and down to check if it is hooked securely.

 **Once correct positioning of the appliance on the bracket has been ensured, proceed with wall fixing.**

- c. Through the screws (V), fix the appliance to the wall in correspondence of the holes with the previously inserted dowels.

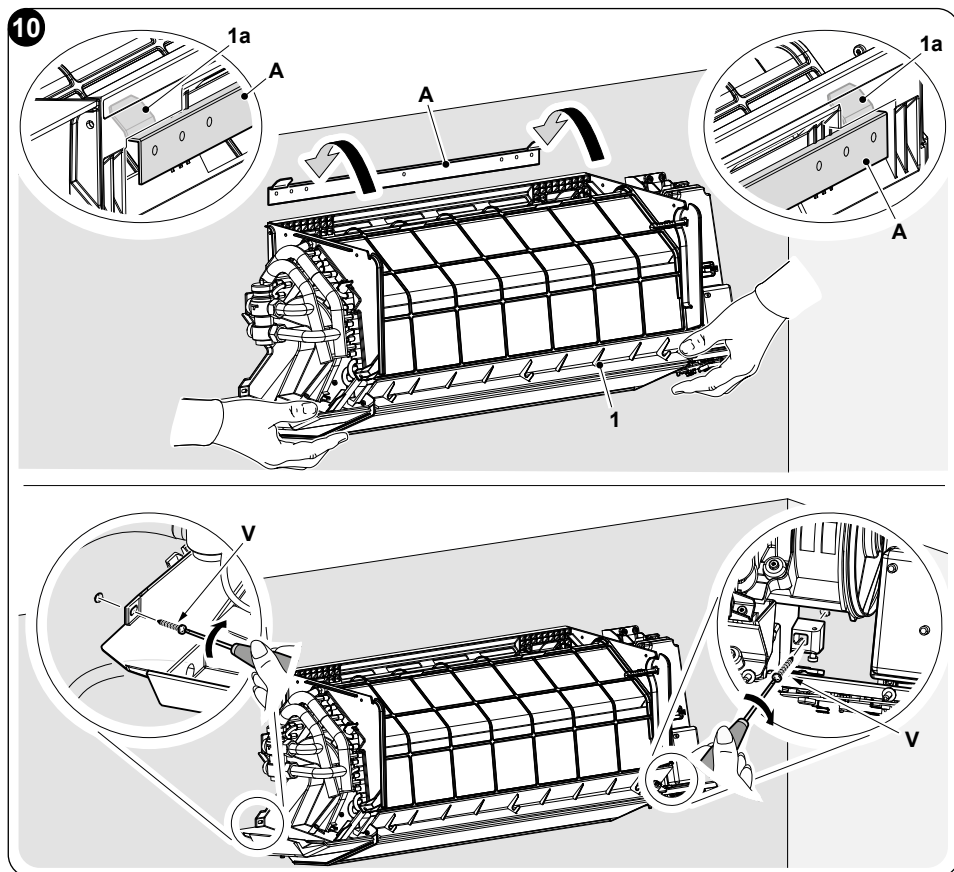

4 - HYDRAULIC CONNECTION

Hoses material	Copper hose		
Model	SLW 1000	SLW 1200	SLW 1400
Connections diameters	1/2"	1/2"	1/2"
Pipelines minimum diameter	20 mm	20 mm	20 mm
Condensation drainage hose connection external diameter	18 mm	18 mm	18 mm



THE HYDRAULIC CONNECTION MUST BE CARRIED OUT BY QUALIFIED PERSONNEL.



- **Use a double wrench to connect the hoses to the unit.**
 - **The use of a flexible hose is recommended for hydraulic connection.**
 - **Accurately insulate both hydraulic connection hoses (fig. 11-12).**
- a. Insulate and connect the water hoses.
 - b. Insulate and collect the condensation drain.

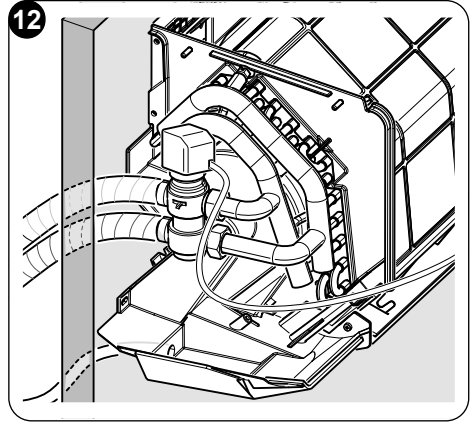
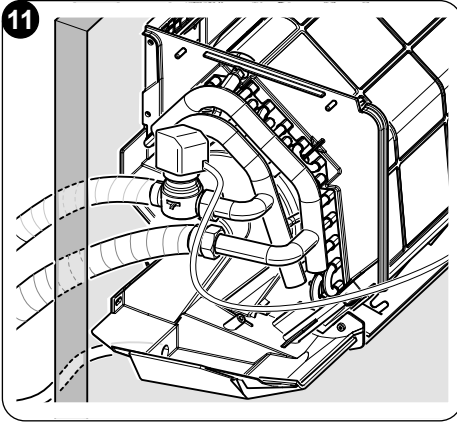

- c. At the first installation, entirely expel air through the bleeding valve (S) (fig. 13).

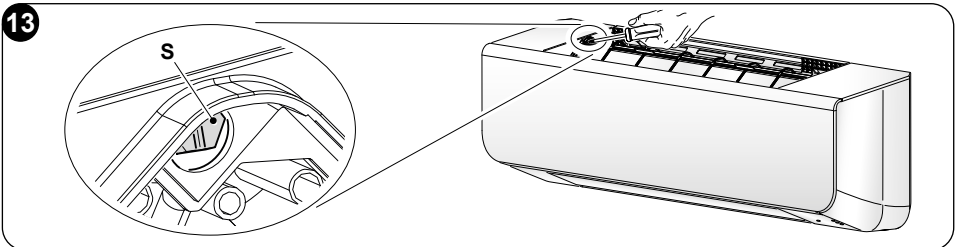



It is advised to repeat the air expulsion operation even after the appliance has worked for a few hours; it is advised to periodically check the system pressure.

4.1 - LOAD LOSSES GRAPH

Unit load losses with the 2-way or 3-way diverter valve in all open position.

Unit load losses with 3-way diverter valve in bypass position.

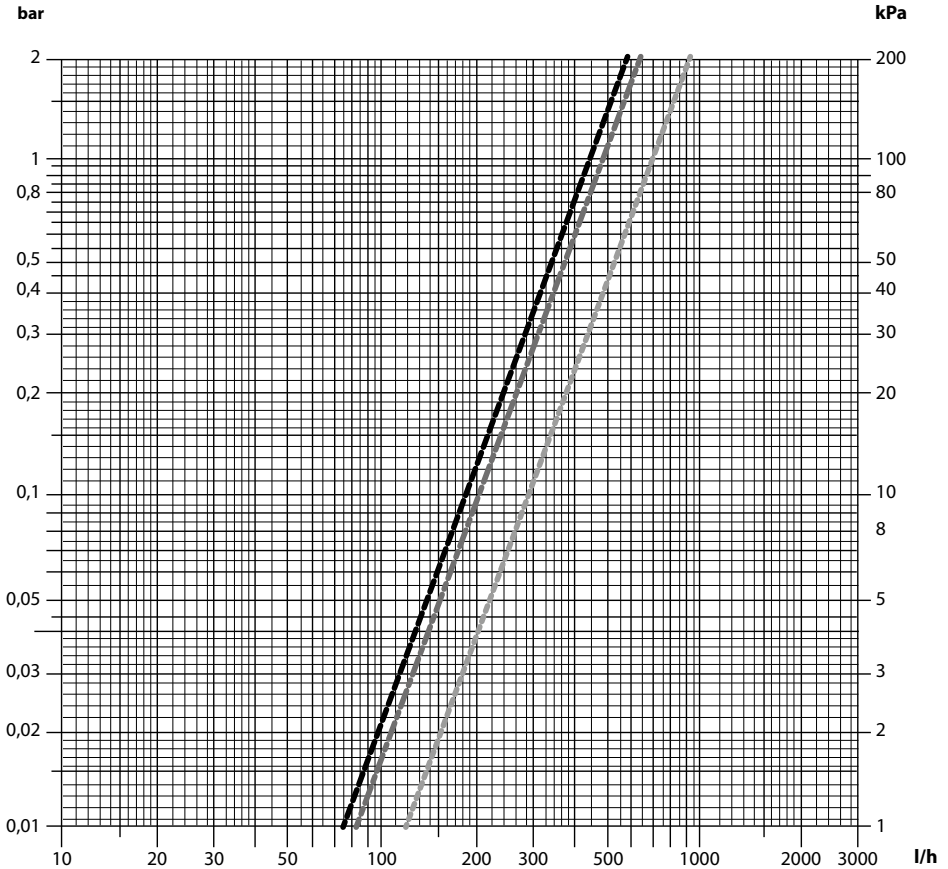

- 1000
- 1200-1400
- V3V in Bypass



5 - ELECTRICAL CONNECTION



Before carrying out any electrical connection, make sure that power supply is disconnected by the units and that the systems to which the equipment must connect are compliant with the current standards.

In case you want to proceed with installation without plug, proceed as described below:

- Use a cable with a minimum section of 3G 0,75
- Use a ground cable at least 20 mm longer than the active wires.
- Connect the ground connection wires to the corresponding terminal.
- Pull the wires to make sure they are connected correctly, then stop them with the specific cable tie.

For correct dimensioning of the guards, please refer to voltage and current consumption indicated on the label located on the unit.



To access the board, remove the screws (12a) and the panel (12b) of the terminal box (12) (Fig.14).

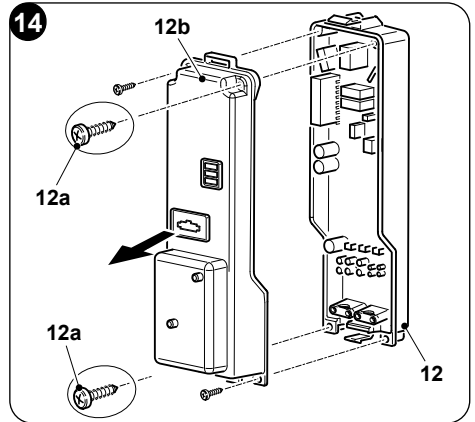

The appliance connection MUST respect the European and national standards and MUST be protected by a 30 mA differential switch.



Connection to the mains supply can be carried out with fixed connection or with mobile plug and MUST be equipped with an omnipolar switch compliant with the current IEC EN standards, with a contact opening of at least 3mm (better if equipped with fuses).



Correct connection to the ground system is essential to ensure safety of the appliance.



Wiring diagram key (fig.15)

- H2:** Water temperature probe
- AIR:** Air temperature probe
- M1:** Fan motor
- M2:** Flap motor
- Y1:** Water 230V-50Hz solenoid valve, max 10W
- Y6 :** Grille safety contact (not used)
- F1:** Fuse
- L:** Line

- N:** Neutral
- S2:** Presence contact input
- A:** Modbus line or presence contact input (yellow)
- B:** Modbus line or presence contact input (orange)
- D1:** Visualization display
- CR:** Remote control
- C:** Hot/cold generator consent contact

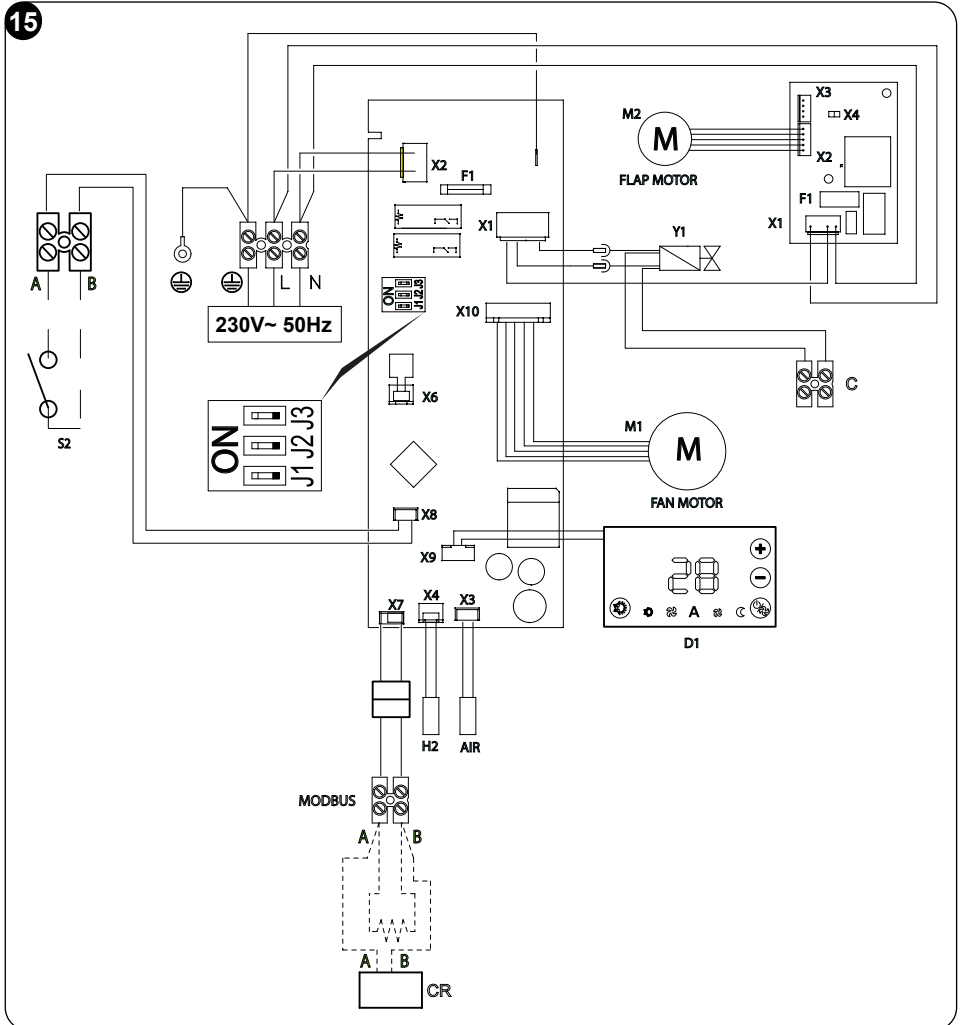

5.1 - CONFIGURATION

The printed circuit board must be configured depending on the type of installation and based on particular operating preferences of the machine.

The three selectors J1, J2 and J3 indicated in fig. 15 must be set as described in the next page:

J1. ON: not settable.

J1. OFF: for appliances without radiant panel: heating occurs always through forced convection, with activation active also in night mode (at reduced speed).

J2. ON: in cooling mode, the fan remains powered even upon reach the desired ambient temperature.

J2. OFF: in cooling mode, the fan id deactivated upon reaching the set temperature.

J3. ON: for appliances to be installed in 2-pipes systems: the board is set for management of a single water valve for summer (cooling) and winter (heating) operation).

J3. OFF: not settable.



The three selectors can be positioned in all the possible combinations since the respective functions are independent from each other.

At each reactivation, the display shows the code corresponding to the setting of the internal selectors for 5 seconds:

D1	C0	C1	C2	C3	C4	C5	C6	C7
J1	OFF	OFF	OFF	OFF	ON	ON	ON	ON
J2	OFF	OFF	ON	ON	OFF	OFF	ON	ON
J3	OFF	ON	OFF	ON	OFF	ON	OFF	ON

5.1.1 - Presence contact input

It is possible to connect the free contact, not live, of a possible presence sensor (not provided) at the closure of which the appliance is deactivated (factory set stand-by), to the terminals "A" and "B" of the internal terminal box (fig. 15).

It is possible, in factory or an authorized assistance centre upon prior request of the customer, to change this function so that the selected ambient temperature is automatically increased (in cooling mode) or decreased (in heating mode) by a specific value "Economy Function" when the contact is closed.













It is not possible to connect the parallel input the one of other circuit boards; use separate contacts.

To connect the presence sensor, it is necessary to use a double-insulated cable with a minimum section of 2x0,5 mm² and maximum length of 20 m. Keep this connection separated from the power supply line of the appliance.

5.1.2 -Hot/cold generator switching on consent contact

The screw connector (C) on the black and grey cables of the thermoelectric head is a free contact (closed = valve open, 230 V max, 1 A max) to give consent for switching on of the hot/cold generator.

5.2 - CONNECTION WITH WIRED REMOTE CONTROL B0736 OR THIRD PARTIES MODBUS

- Connect the cables coming from the “**A B**” connection of the B0736 command with the respective wires on the mammoth connected to the panel lid, taking care to respect the polarity, yellow cord “**A**” and orange cord “**B**”, connecting the farthest unit with the 120 Ohm resistor supplied with the appliance.
- Enable Remote configuration (paragraph “5.4”, configuration parameter “CF”).
- All the commands “   ” shall be disabled and the message “rE” will appear on the display every time they are activated.
- The indicator “” shows the chosen mode of operation, the indicators “”, “**A**”, “” and “” and the set fan speeds.
- As regards the functionalities and settings, see the instructions of command B0736.

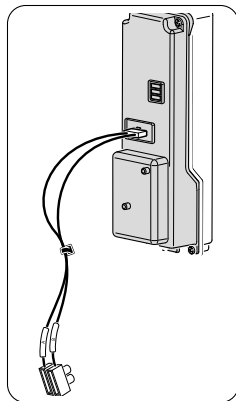

5.3 - CONNECTION WITH SIOS CONTROL

- Connect the cables coming from the “**A B**” connection of SIOS CONTROL with the respective wires on the mammoth connected to the panel lid, taking care to respect the polarity, connecting the farthest unit with the 120 Ohm resistor supplied with the appliance.



- Enable Autonomous configuration (paragraph “5.4”, configuration parameter “CF”).
- Set the protocol type ASCII if SIOS CONTROL envisages B0863 or RTU if SIOS CONTROL does not envisage B0863 (paragraph “5.4”, configuration parameter “bU”).
- Set the address, each appliance must have an address different from all the other units connected to the same BUS (paragraph “5.4”, configuration parameter “Ad”).
- As regards mounting of the connections, proceed by following the indications described in the previous paragraphs.













Once the operations have been completed, reposition the previously disassembled parts, taking care to connect the display connector and the earth connection cable. Secure the front shell through the 6 screws, then feed the machine.



- ***When the unit is configured for remote control, the remote controller is disabled.***
- ***It is not possible to control the flap from remote control.***
- ***In this mode, the air probe installed on board the fan coil is ignored.***

5.4 - BOARD SOFTWARE CONFIGURATION

Work as follows:

- a. Connect power supply, then ensure that the latter is set to any mode except for stand-by.
- b. On the control panel, simultaneously press the key “” (T2) and “” (T1) for at least 5 seconds, until an acoustic signal is emitted.
- c. The display shows the reference to the parameter
- d. Scroll using the key “” or “” (T1) until you select the desired parameter
- e. Press the key “” or “” (T1) to scroll the list of parameters: CF -> bU -> Ad -> Fa -> Po -> co -> CF -> ...
- f. Press key “” (T2) to access the value
- g. Release and press key “” (T2) for more than 3 seconds to change the value (Display blinking)
- h. Press key “” or “” (T1) to scroll the possible values of the parameters
- i. Press key “” (T3) to confirm the value
- j. Press key “” (T3) to exit the configuration or wait 20 seconds.



Quit and give power voltage to the system to start the unit under the new configuration.



ID	Name	Description	Permitted values
CF	Configuration	Configure the type of control	AU : Autonomous rE : Remote
bU	Bus Protocol	Allows to configure the type of bus used	AS : ASCII rt : RTU
Ad	Unit Address	Allows to set/change the unit address (insert the value in hexadecimal format)	00 -> FF (255)
Fa	Fancoil Type	Allows to select the type of fancoil	_0: SLW 1000 - 1200 - 1400 _1: not settable _2: not settable
Po	Position of installation	Allows to select where the fancoil has been installed	uP : High wall assembly dO : not settable
co	Ambient temperature compensation	Allows to choose the compensation value to use	-5 : 5

bU – BUS Protocol:

Modicon Modbus™ ASCII type	Modicon Modbus RTU type
Baudrate = 9600	Baudrate = 9600
data bits = 7	data bits = 8
stop bit = 1	stop bit = 1
equality = si	equality = no

Ad - Unit Address:

In the event of need, it is possible to change the unit address.

The value must be entered in hexadecimal format. The table below indicates the conversion of the first 80 numbers from decimal to hexadecimal format, for the next numbers, please refer to the specific tables which can be consulted on the web.

Decimal	Hexadecimal
1	01
2	02
3	03
4	04
5	05
6	06
7	07
8	08
9	09
10	0A
11	0B
12	0C

Decimal	Hexadecimal
13	0D
14	0E
15	0F
16	10
17	11
18	12
19	13
20	14
21	15
22	16
23	17
24	18

Decimal	Hexadecimal
25	19
26	1A
27	1B
28	1C
29	1D
30	1E
31	1F
32	20
33	21
34	22
35	23
36	24

>>>>



Decimal	Hexadecimal
37	25
38	26
39	27
40	28
41	29
42	2A
43	2B
44	2C
45	2D
46	2E
47	2F
48	30
49	31
50	32
51	33

Decimal	Hexadecimal
52	34
53	35
54	36
55	37
56	38
57	39
58	3A
59	3B
60	3C
61	3D
62	3E
63	3F
64	40
65	41
66	42

Decimal	Hexadecimal
67	43
68	44
69	45
70	46
71	47
72	48
73	49
74	4A
75	4B
76	4C
77	4D
78	4E
79	4F
80	50

Co – temperature compensation:

If the particular installation of the unit requires it, it is possible to add compensation on the reading of ambient temperature from -5°C to $+5^{\circ}\text{C}$ active in any mode, except for automatic mode.

 ***If the unit has a roof configuration, the unit has a default compensation of -3°C which can be changed by the installer.***

6 - OPERATING CONDITIONS

For safe and effective operation, use the appliance at the following temperatures.

Mode	Water inlet temperature
Cooling	$3^{\circ}\text{C} - 20^{\circ}\text{C}$
Heating mode	$30^{\circ}\text{C} - 70^{\circ}\text{C}$

-  • ***If the appliance is not used within the values indicated, operating anomalies may occur.***
- ***It is normal that condensate forms on the surface of the appliance when the level of humidity in the room is high; in this case, close doors and windows.***
 - ***Operating pressure of the hydraulic system: Max: 10 bar - Min: 1,5 bar***



7.3 - REMOTE CONTROL KEYS (Fig.18)

- **B1:** ON/Standby
- **B2:** Operating mode selection (cooling => fan => heating)
- **B3:** Flap position selection (only models with Flap)
- **B4:** Increase temperature
- **B5:** Decrease temperature
- **B6:** Fan speed selection (max speed => medium speed => min speed => auto....)
- **B7:** LED
- **B8:** Unit programmed switching on setting
- **B9:** Unit programmed switching off setting
- **B10:** Unit programmed switching on/off confirmation/cancellation
- **B11:** Night mode selection (on/off)

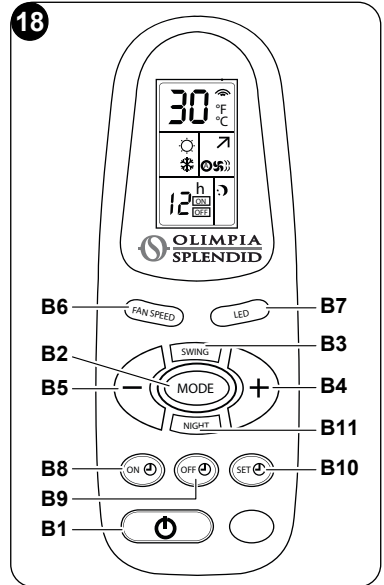

7.4 - USE OF THE REMOTE CONTROL

The remote control provided with the appliance is the tool which allows You to use the equipment in the most comfortable manner. It should be handled with care and in particular:

- Keep it dry (do not clean it with water or leave it outdoors in bad weather).
- Avoid dropping or bumping it.
- Keep it out of direct sunlight.

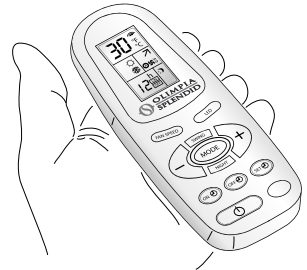

- ***The remote control operates by means of an infrared beam.***
- ***During use, do not interpose obstacles between the remote control and the appliance.***
- ***If other appliances in the room have remote controls (TV, stereo, etc...), there may be interference with consequent loss of the sent signal.***
- ***Electronic and fluorescent lamps may interfere in the transmissions between remote control and appliance.***
- ***Remove the batteries in case of prolonged disuse of the remote control.***



7.4.1 -Insertion of batteries

To insert the batteries correctly (fig. 19):

- a. Remove the batteries compartment cover.
- b. Insert the batteries into the relevant compartment.

 **Check the polarity indicated on the bottom of the compartment.**

- c. Close the compartment correctly.

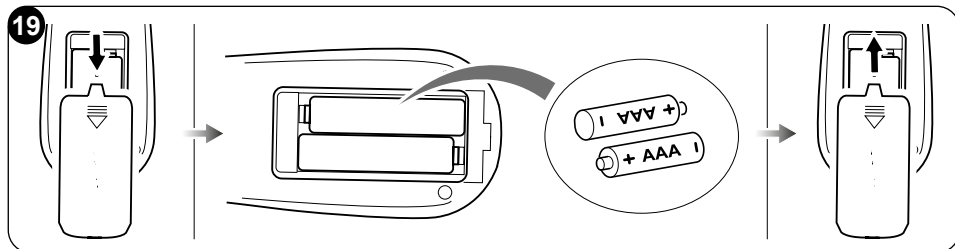

7.4.2 -Replacement of batteries

The average life-span of the batteries, with normal use, is approx. six months.

Replace the batteries when the “beep” for reception of the command from the appliance is no longer heard.

 **Always use new batteries and replace both at the same time. The use of old or different batteries could generate malfunctioning of the remote control.**

The remote control uses two dry alkaline 1.5V batteries (AAA.LR03) (fig. 19).



When replacing batteries, replace both and dispose of the dead batteries in the appropriate collection centres and as required by law.

- If the remote control is not used for several weeks or longer, remove the batteries. Any leaks from the batteries could damage the remote control.



Do not re-charge or disassemble the batteries. Do not throw the batteries into the fire. They can burn and explode.



If the battery liquid falls onto the skin or clothes, wash well with clean water. Do not use the remote control with batteries that have leaked. The chemical products contained in the batteries can cause burns or other risks to health.



7.4.3 - Location of the remote controller

- Keep the remote control in a position from which the signal can reach the appliance receiver (maximum distance is about 8 meters - with charged batteries) (fig. 20). The presence of obstacles (furniture, curtains, walls, etc.) between the remote control and the appliance reduces the remote control range.

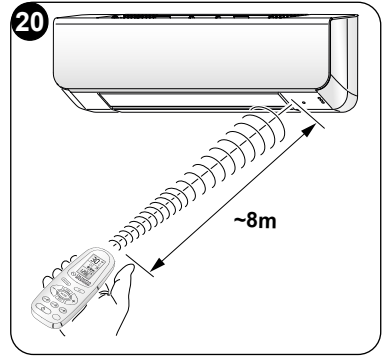

7.5 - APPLIANCE SWITCHING ON/OFF

In the event that a main switch has been installed on the power line, it must be switched on.

- To switch on/off the appliance, press the “” (T2) key for 2 seconds.
- The appliance can be switched on or off by pressing key “B1” on the remote controller.

All the timers are reset when the appliance is switched off.

The absence of any light signal identifies the ‘stand-by’ status, absence of function. When the control is set to this mode of operation, it ensures safety against freezing. In the event that ambient temperature drops below 5°C, the hot water solenoid valve and the fan motor at minimum speed are activated, the display shows code “AF”.

7.6 - AUTOMATIC COOLING /HEATING MODE

Setting this type of adjustment allows the control to automatically carry out the selection of cooling or heating mode, based on the difference between temperature set by the user and ambient temperature.

- To activate/deactivate this function, keep the cooling/heating selection key “T3” pressed for 10 seconds until the blue and red symbols (A5) light up alternatively. This setting is maintained also in the event of power interruption.
- Then, ensure that when the set temperature is changed, the unit alternates cooling only (blue indicator “A5” on), fan (blue and red indicators off) or heating only (red v “A5” on) mode.

In this mode, read ambient temperature compensation is disabled.

This setting can only be carried out from the panel on board the machine.



If automatic mode is active, it is not possible to change the operating mode from the remote controller.



7.7 - MANUAL COOLING/ HEATING MODE

From board the machine

- To activate/deactivate this function, keep cooling/heating selection key "T3" pressed for 10 seconds until the blue and red symbols (A5) light up alternatively.
This setting is maintained also in the event of power interruption.
- Pressing key "T3" for 2 seconds allows to cyclically select cooling (blue LED), heating (red LED) or fan (red LED and blue LED off) mode.

From remote controller

- To select this function, press the key "B2" until the heating only (D10) or cooling only (D11) symbol appears on the remote controller.

From the remote controller it is not possible to change setting from manual mode to automatic mode.

7.8 - FAN MODE

When this mode is used, the appliance does not exercise any action on temperature or air humidity in the room, but only keeps it in circulation.

From board the machine

- Pressing key "T3" for 2 seconds allows to cyclically select cooling (blue LED), heating (red LED) or fan (red LED and blue LED off) mode.
- Under this operating mode, the internal fan is always on and it is possible to select the desired speed of the fan at any moment by pressing the specific key "T2".



The desired temperature which operates on the automatic speed of the fan can be selected only from board the machine: the more the desired temperature deviates from ambient temperature, the more the fan speed is high.

These are the possible speeds for the fan.



MAXIMUM speed



MINIMUM speed



AUTO speed



From remote controller

- a. This function can be selected by pressing key “**B2**” until when the two heating (D10) or cooling (D11) symbols are both off.
- b. Under this operating mode, the internal fan is always on and it is possible to select the desired speed of the fan at any moment by pressing the specific key “**B6**”.



In fan mode, the solenoid valve remains disabled, while the fan is activated at the set speed.

7.8.1 -Operation at maximum speed**From board the machine**

- a. To select this mode, press key “” (T2) several times until the indicator (A4) activates.
- b. With this mode it is possible to obtain the maximum supplied power both in cooling and heating modes (the fan motor is always activated at maximum speed).

From remote controller

- a. To select this mode, press key “**B6**” several times until the indicator (D6) activates completely.



7.8.2 -Operation at AUTO speed**From board the machine**

- a. To select this mode, press key “” (T2) several times until the indicator (A3) activates.
- b. In this mode, the fan speed adjustment is completely automatic between a minimum and maximum value, according to the heating or cooling needs of the room.

From remote controller

- a. To select this mode, press key “**B6**” several times until the indicator (D5) activates.

7.9 - NIGHT OPERATION**From board the machine**

- a. To select this mode, press key “” (T2) several times until the indicator (A1) activates.
- b. The function deactivates automatically when the fan speed is changed by means of the key “” (T2).



From remote controller

- a. To select this mode, press key "B11" until the indicator (D7) activates.
- b. To be able to change ventilation speed, it is necessary to disable the function by pressing key "B11" first.

When this function is enabled, the internal fan is controlled by the appliance automatically and the set ambient temperature is automatically changed as follows:

- decreased by 1°C after one hour and by another degree after 2 hours in heating function;
- increased by 1°C after one hour and by another degree after 2 hours in cooling function.

7.10 - MEANING OF BLINKING AND OPERATION OF THE LED

- The blinking LED (A5) indicates that the request for water (hot or cold) has not been met and causes the stop of the fan as long as water temperature does not reach an appropriate value which can meet the request.
- The alternate switching on of the red and blue LEDs (A5) indicates that the automatic cooling/heating mode is active.
- The 4 LEDs "☁", "A", "☁" and "☾" indicate the set fan speed. If all the 4 LEDs are off, Stand-by mode is active.

Each of these LEDs is active in blinking mode (soft-blinking) if during heating or cooling (red or blue LEDs "A5" ON) the set temperature is respectively lower or higher than the ambient temperature detected by the appliance.



To increase comfort at night, the LEDs brightness on the electronic panel is decreased after 15 seconds of inactivity on the keys or on the temperature selector.

Only from remote controller, press key "B7" to be able to switch off the LEDs on the control panel after 15 seconds of inactivity on the keys.

Every time the keys are pressed on the control panel, the LEDs brightness returns at maximum level over the following 15 seconds.

7.11 - SWING OPERATION

- a. Press the key "B3", the icon (D9) lights up and the flap starts to oscillate. Press key "B3" again, the icon (D9) switches off and the flap stops oscillation, stopping in the position it reached at that moment.





If the fan is switched off while the flap is set to swing mode, the swing stops and restarts when the fan is switched on again.





This function can only be activated/deactivated from the remote controller.

7.12 -SPECIAL FUNCTIONS

7.12.1 - Air sampling

In heating or cooling mode and with ambient temperature higher or lower than the desired value, the fan is periodically powered for 1 minute at minimum speed. This way, the system is able to adequately keep temperature in the room under control and to reactivate faster in case of need.

7.12.2 - Commands lock

To lock the keys on board the machine, keep keys “ | ” (T1) pressed simultaneously for 5 seconds.

The activation of the function is verified by the visualization of (BL) on the display every time any key is pressed.



This function can only be activated/deactivated from board the machine.

7.12.3 - Water not suitable

The effective operation of the appliance in cooling or heating mode is always conditioned by temperature of water circulating inside the system. If water temperature does not reach a value suitable for the set mode, so if water is too hot in cooling mode or too cold in heating mode, the fan motor remains off and the indicator of the current mode (A5) blinks.

- The function is active in cooling mode if the unit is not thermostatic and if water temperature in the battery is higher than 20°C from more than 5 minutes. The unit immediately resumes normal operation of one of the two conditions is not met anymore.
- The function activates in heating mode if the unit is not thermostatic and if water temperature in the battery drops under 30°C (the fan stops immediately).

In heating mode, the unit restarts normal operation only if temperature is higher than 30°C for at least 30 seconds



7.12.4 - Water probe inhibition

If a particular system requires it, it is possible to inhibit the control of the unit on unsuitable water temperature.

- Disconnect the unit from the power supply.
- Disconnect the battery probe from the connector X4
- Switch on the unit and wait that the alarm "E3" appears on the display.
- Press keys "T2" and "T3" simultaneously for at least 10 seconds, at this point the alarm is disabled and the display shows the desired temperature.

To reactivate the control of water temperature (from disconnected machine), it is necessary to reconnect the probe.

7.13 - OPERATION WITH TIMER (delayed switching on and switching off)

This mode allows to program the unit switching on and switching off

The delay time can be set, activated and cancelled from the remote controller.

7.13.1 - Setting of the switching on timer from remote controller

- a. After switching on the unit, select the operating mode, desired temperature and fan speed with which the unit will reactivate at the programmed switching on.



Then, set the machine to Stand-By mode.

- b. Press key "B8" to set the desired delay (from 1 to 24 hours) after which the unit will switch on starting from timer confirmation.

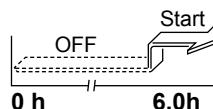

- c. If no key is pressed within 5 seconds, the timer setting function will end automatically.

- d. The remote controller display shows the countdown for switching on while the display of the fan coil shows the message "tl".

Once the set time passes, the unit will start with the last selected settings.

7.13.2 - Setting of the switching off timer from remote controller

- a. With the unit set to any operating mode, press key "B9" to set the desired delay (from 1 to 24 hours) after which the unit will switch off starting from timer confirmation.



- b. If no key is pressed within 5 seconds, the timer setting function will end automatically.

- c. The remote controller display shows the countdown for switching off while the display of the fan coil shows the message "tl".

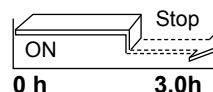

Once the set time passes, the unit will switch off.

7.14 -SWITCHING OFF FOR PROLONGED PERIODS

If the appliance is not used for a prolonged period of time, it is necessary to carry out the following operations:

- a. Set the main switch of the system to "off".
- b. Close the water valves.
- c. If the risk of frost exists, make sure that antifreeze liquid has been added to the system, empty the system otherwise.



The antifreeze function is not active.

7.15 -ALARMS KEY

ALARMS	A6 (white)
Main board communication error	E1 (B) -> Contact assistance
Ambient temperature sensor alarm	E2 (B) -> Contact assistance
Water temperature sensor alarm	E3 (B) -> Contact assistance
Fan motor alarm	E4 (B) -> Contact assistance
Serial port communication error	E5 (B) -> Contact assistance
Air grille switch alarm	E6 (B) -> Contact assistance
Dirty filter alarm	-> Select the program stand-by -> Clean the air filter as described on the maintenance manual of the machine F1 (B) -> Switch the unit on and keep keys "T2" and "T3" pressed for 5 seconds until normal operation is restored.

(B) : Air grille switch alarm

8 - MAINTENANCE AND CLEANING



Always make sure the appliance has been disconnected electrically before proceeding with any maintenance or cleaning intervention.



Do not touch the metal parts of the appliance when you remove the filter.
There is a risk of injury due to the sharp metal edges.



Do not use water to clean the internal parts of the air conditioner.
Exposure to water can ruin the isolation, with the risk of electric shocks.



8.1 - CLEANING

8.1.1 -Cleaning the appliance and the remote control

- Use a dry cloth to clean the appliance and the remote control.
- It is possible to use a cloth moistened with cold water to clean the appliance if the latter is very dirty.



Do not use a chemically treated or antistatic cloth to clean the appliance. Do not use gasoline, solvent, polish or similar solvents. These products could cause the breakage or deformation of the plastic surface.

8.1.2 -Cleaning the air filter

In order to guarantee effective indoor air filtration and good working order of your appliance, it is essential to periodically clean the air filters (7) every 2 weeks (in conditions of frequent use). Operate as follows:

- From the opening located in the upper part of the unit, extract the filter unit (7) through the tabs (7a) located on the filter holder chassis (8) (Fig.21).

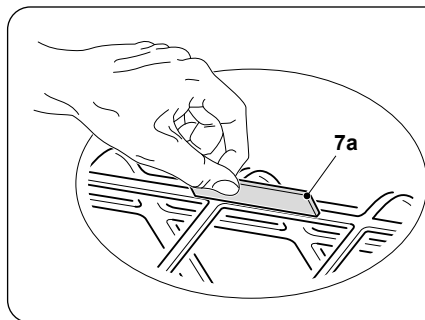
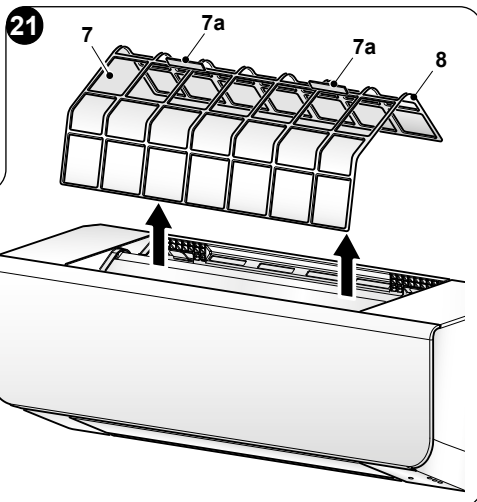

- The filters (7) must be washed using a jet of water facing in the direction opposite to that of the accumulation of dust or cleaned using a suction device (Fig.22).
- If the dirt is particularly difficult to remove (such as grease or deposits of other types) the filters must be previously immersed in a solution of water and neutral detergent.

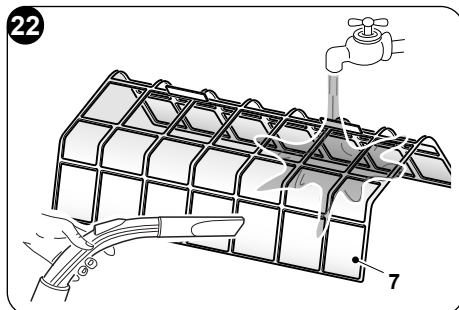

- d. Before re-introducing the filters, it is good practice to shake them to eliminate the water accumulating during washing.



If the filters (7) are damaged, replace them.

- e. Make sure that the filters (7) are completely dry.
- f. Re-position the filters (7) correctly in the relative seats.
- g. Suck possible fluff from the grille.



Do not use the appliance without the filter (7).

8.2 - MAINTENANCE

If you do not intend to use the appliance for a long period of time, work as follows:

- a. Activate the fan only mode for a few hours (approximately 8÷10 hours) to dry the interior of the appliance.
- b. Stop the air appliance and disconnect the power supply.
- c. Clean the air filter.
- d. Remove the batteries from the remote control.

Checks before resuming use of the air conditioner:

- a. Clean the filters after a long period of inactivity of the air conditioner.
- b. Check that the air outlet or inlet are not obstructed (especially after a long period of inactivity of the air conditioner).

9 - TROUBLESHOOTING

If one of the following anomalies occurs, switch the appliance off, disconnect it from the electric power supply and contact your dealer.

- a. A safety device, such as a fuse or switch, intervenes frequently.
- b. The appliance has a water leak.
- c. Other malfunctioning.

9.1 - SYMPTOMS THAT DO NOT INDICATE APPLIANCE MALFUNCTIONING

White mist escaping from the appliance

If the cooling function is started in a room with high humidity level and the inside of the appliance is very contaminated, the distribution of the temperature is not regular. In this case, it will be necessary to clean the inside of the appliance.

Contact your dealer for additional details regarding cleaning the appliance.

This operation requires a qualified professional.



Noise level during operation

- a. The appliance emits a low and continuous noise, like hissing, in cooling mode or when stopping.
This noise is caused by operation of the drain pump (optional accessory).
- b. The appliance emits a squealing noise, like a squeak, when the system stops after operation in heating mode.
This noise is caused by the expansion and contraction of the plastic parts due to temperature changes.

Dust escaping from the appliance

- a. This occurs when the appliance is used for the first time after a long period of time and depends on the accumulation of dust inside the appliance

The appliance gives off odours

- a. The appliance can absorb the odour of rooms, furniture, cigarettes, etc. and return them to the environment.

9.2 - INCONVENIENCES AND POSSIBLE REMEDIES

Consult the following points before requesting assistance or repairs.

MALFUNCTIONING	CAUSE	WHAT MUST BE DONE?
Ventilation activation is delayed with respect to the new temperature or function settings.	- The circuit valve requires a certain time for its opening and therefore to make hot or cold water circulate in the appliance.	- Wait 2 or 3 minutes so that the circuit valve opens.
Ventilation speed increases or decreases automatically.	- The electronic control works so as to adjust the best level of comfort.	- Wait for temperature adjustment or select silent function in case of need.
The appliance does not start ventilation.	- Hot or cold water is missing in the system.	- Check that the boiler or the water refrigerator are operational.
The fan does not activate even if there is hot or cold water in the hydraulic circuit.	- The hydraulic valve remains closed.	- Dismount the valve body and check if water circulation is restored. - Check the operating status of the valve by powering it separately at 220 V. If it activates, the problem may be in the electronic control.
	- The ventilation motor is locked or burned out.	- Check the motor windings and the free rotation of the fan.
	- The electrical connections are not correct.	- Check the electrical connections.

>>>>



MALFUNCTIONING	CAUSE	WHAT MUST BE DONE?
The appliance loses water during heating function.	- Losses in the water connection of the system.	- Check the loss and firmly tighten the connections.
	- Losses in the valves unit.	- Check the status of the seals.
Dew formations are present on the front panel.	- The thermostatic valve integrated in the connection unit between panel and battery does not close flow towards the wall.	- Replace the junction which integrates the thermostatic valve in the water inlet upper unit.
	- Thermal insulators are disconnected.	- Check for correct positioning of the thermoacoustic insulators, paying particular attention to the front one above the finned battery.
A few water drops are present on the air outlet flap.	- In situations of high relative ambient humidity (>60%) condensation phenomena may occur, especially at minimum ventilation speeds.	- Once relative humidity drops, the phenomenon disappears. In any case, the possible fall of some water drops inside the appliance does not indicate a malfunction.
The appliance loses water during cooling only function.	- The condensation basin is clogged.	- Slowly pour a water bottle in the bottom part of the battery to ensure drainage; if necessary, clean the basin and/or improve inclination of the drain pipe.
	- The condensation drain has not the necessary inclination for correct drainage.	
	- The connection pipelines and the valves unit are not insulated correctly.	- Check for insulation of the pipelines.
The appliance emits excessive noise.	- The fan touches the structure.	- Check for possible interferences by manually rotating the fan.
	- The fan is unbalanced.	- Unbalancing determines excessive vibrations of the machine: replace the fan.

Do not try to repair the appliance by yourself.

If the problem has not been solved, please contact your local retailer or the closest assistance service. Supply detailed information about the malfunction and the equipment version.



OLIMPIA SPLENDID spa
via Industriale 1/3
25060 Cellatica (BS)
www.olimpiasplesndid.it
info@olimpiasplesndid.it

I dati tecnici e le caratteristiche estetiche dei prodotti possono subire cambiamenti. Olimpia Splendid si riserva di modificarli in ogni momento senza preavviso.