

Note 1:
Inside all tapping :
-No burr
-No paint

Note 2 :
No burr and any sharp edge on part surface.
Refer to DIN 2768 / M for unspecified tolerances.

Note 3 :
Frame is shown without coating.
Color : White (RAL 9016)
Coating thickness is 70µm ±20 on tube per layer
Coating thickness is 120µm ±50 on collector per layer
Maximum acceptable coating is 2 layers.

Note 3:
For 1785 mm product: 0,00736 kg of paste will be used.
For 1600 mm product: 0,00644 kg of paste will be used.
For 1188 mm product: 0,00483 kg of paste will be used.
For 803 mm product: 0,00322 kg of paste will be used.
For 650 mm product: 0,00299 kg of paste will be used.

Model	L	I	Surface Roughness
BOLZANO STRAIGHT FRAME WP 803X450	450	400	For Chrome Coating, Maximum Surface Roughness: 0.4 µm For Paint, Maximum Surface Roughness: 1.2 µm
BOLZANO STRAIGHT FRAME WP 803x500	500	450	
BOLZANO STRAIGHT FRAME WP 803x550	550	500	
BOLZANO STRAIGHT FRAME WP 803x600	600	550	
BOLZANO STRAIGHT FRAME WP 1188X450	450	400	
BOLZANO STRAIGHT FRAME WP 1188x500	500	450	
BOLZANO STRAIGHT FRAME WP 1188x550	550	500	
BOLZANO STRAIGHT FRAME WP 1188x600	600	550	
BOLZANO STRAIGHT FRAME WP 1188x750	750	700	
BOLZANO STRAIGHT FRAME WP 1600X450	450	400	
BOLZANO STRAIGHT FRAME WP 1600x500	500	450	
BOLZANO STRAIGHT FRAME WP 1600x550	550	500	
BOLZANO STRAIGHT FRAME WP 1600x600	600	550	
BOLZANO STRAIGHT FRAME WP 1600x750	750	700	
BOLZANO STRAIGHT FRAME WP 1785X450	450	400	
BOLZANO STRAIGHT FRAME WP 1785x500	500	450	
BOLZANO STRAIGHT FRAME WP 1785x550	550	500	
BOLZANO STRAIGHT FRAME WP 1785x600	600	550	
BOLZANO STRAIGHT FRAME WP 1785x750	750	700	

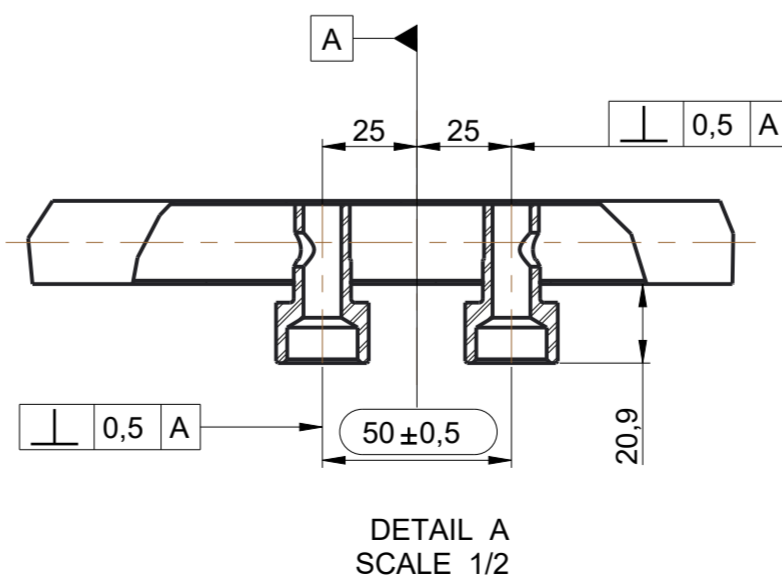
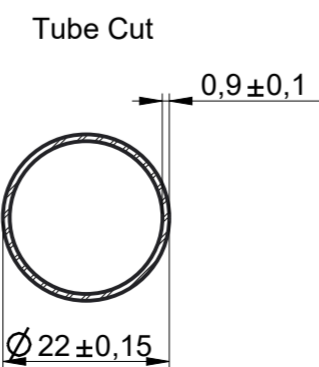
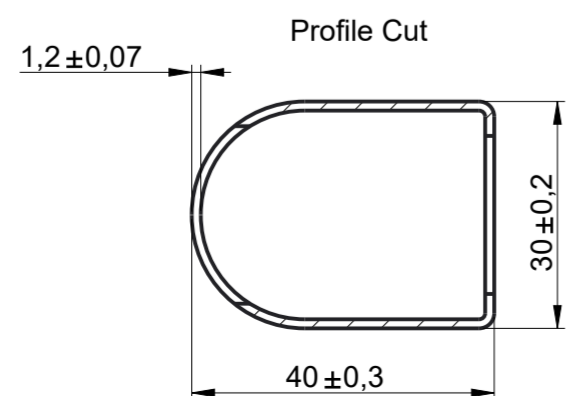
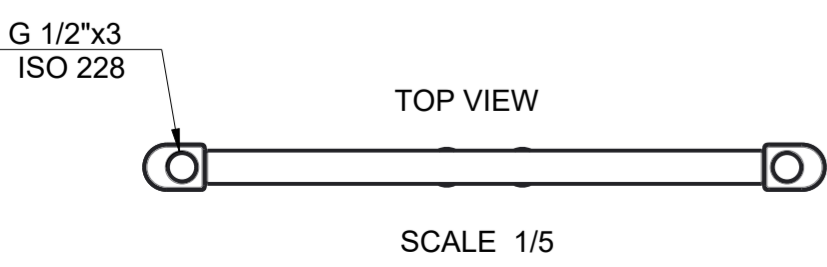
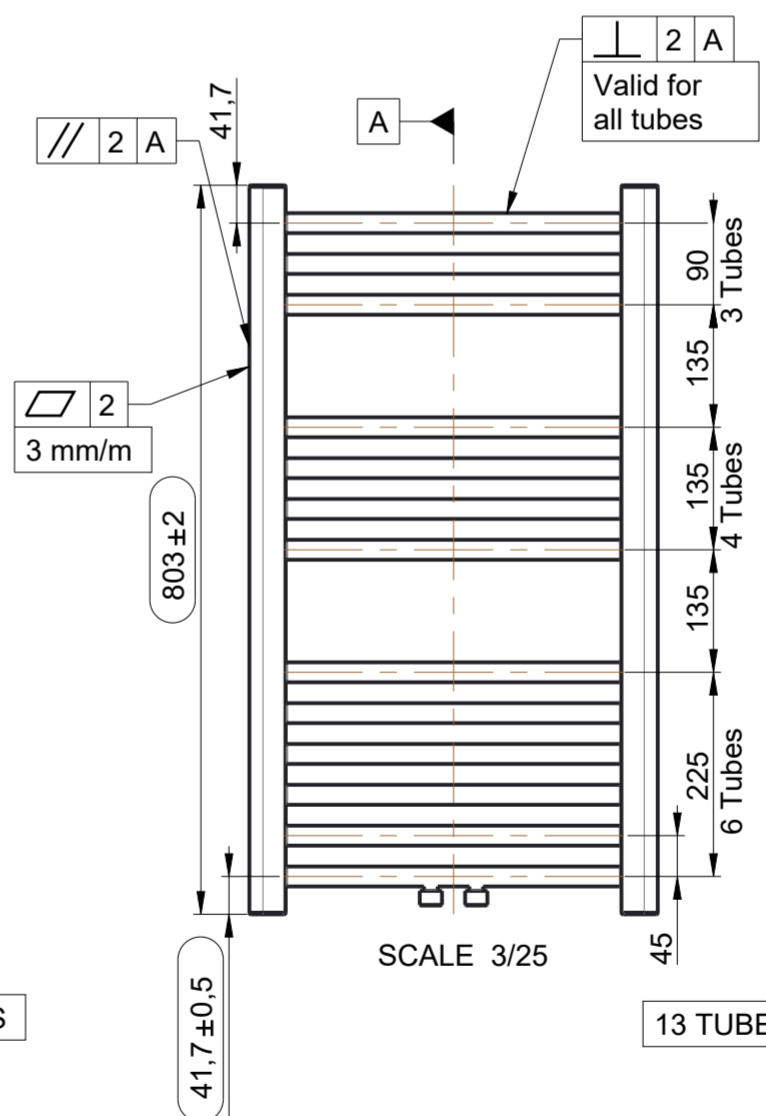
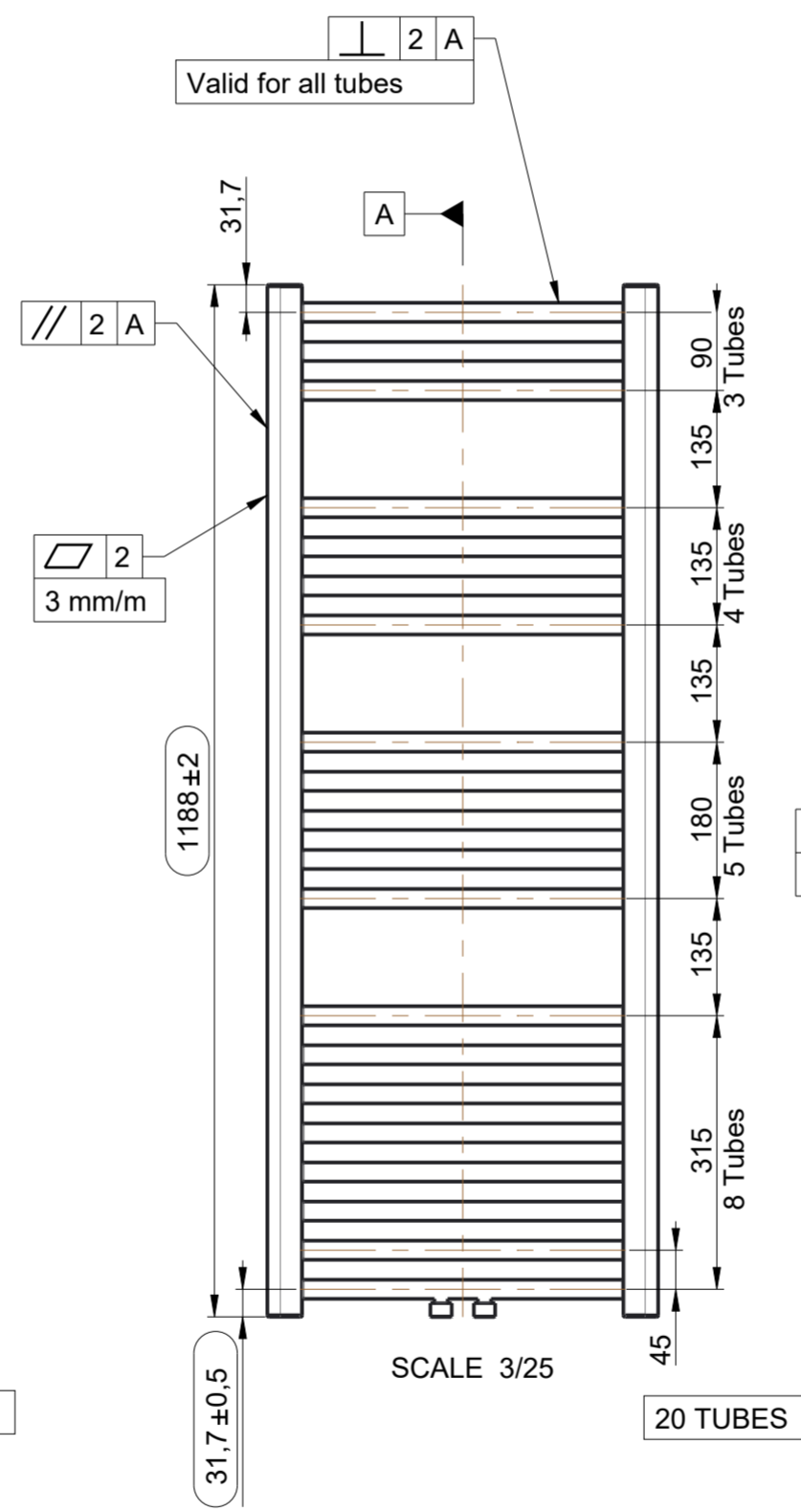
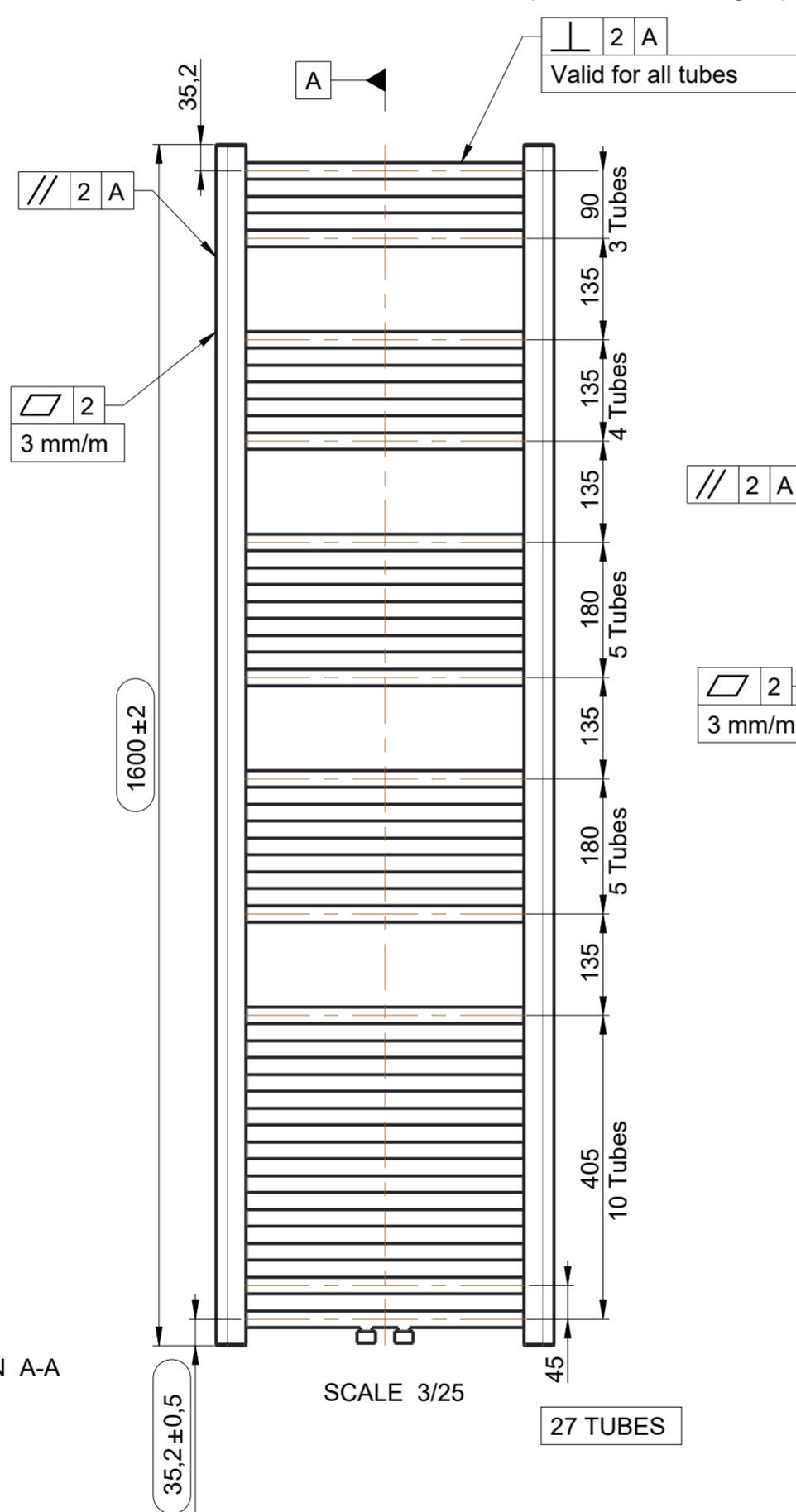
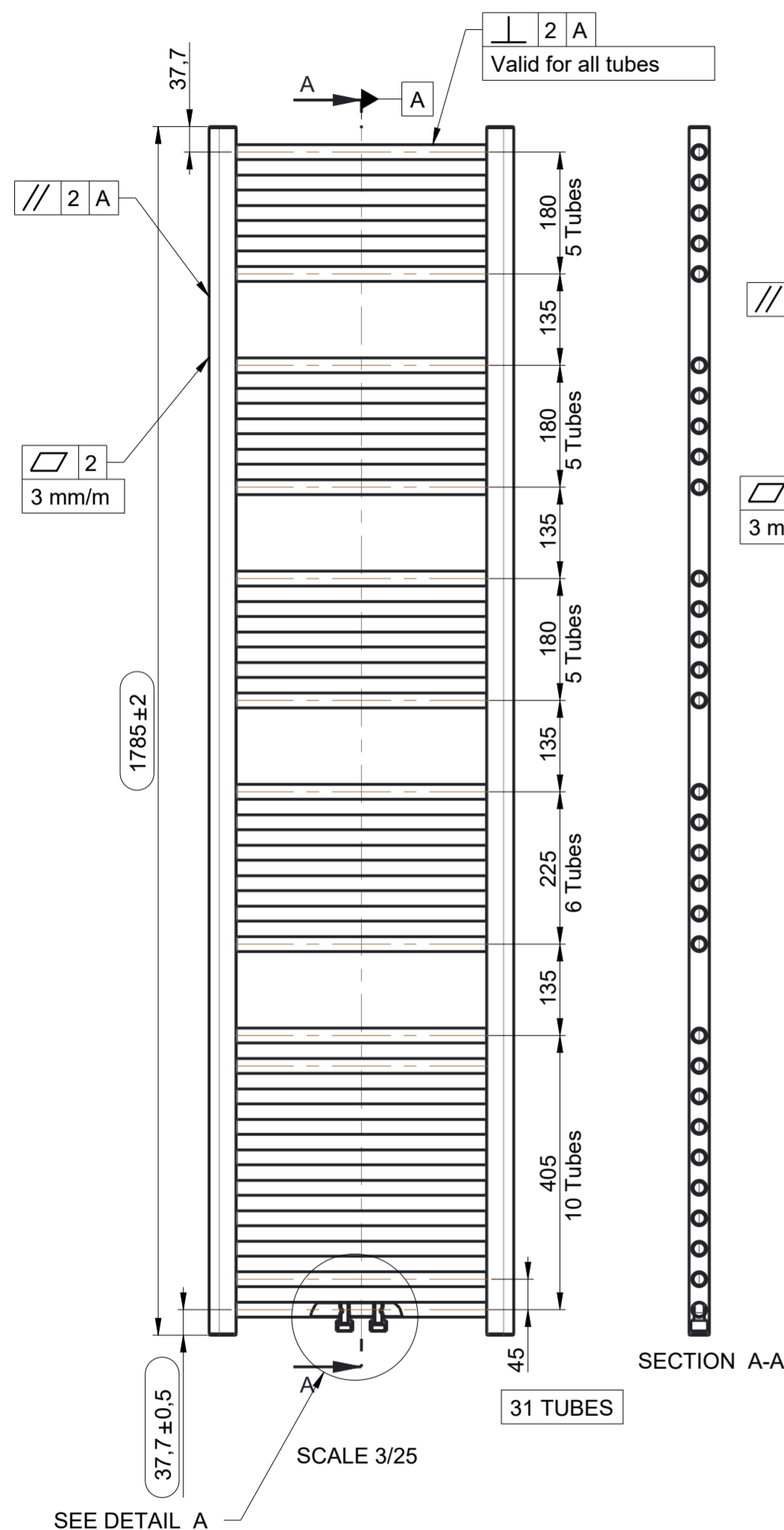

Ind	Date	Modification	Modif/Demand	Modif by
A	19.10.2018	Creation of drawing	-	muraty
		Weight:	Material:	
Code: BOLZANO 4T - DR WP		drawn by: stgizmr	checked by: mgays	status
creation date	19.10.2018	BOLZANO 4 FORI - dritto attacchi centrali BOLZANO 4 TAPS - straight central connections BOLZANO 4 STOPFEN - gerade mittelanschluß		ERP ID
size	A2	scale	1/1	PLM ID
This drawing can't be, without authorization, neither copied, neither reproduced, or communicated to thirds. Law of July 14, 1909 on the drawings and the models.				