



Built-In Fan Coil Installation Guide



Built-In Fan Coil Installation Guide

This installation guide is intended to support the installation of FC-HBI/VBI Built-In fan coils in horizontal or vertical installation. This guide should be consulted alongside the manufacturers manual and any system design documents.

Contents

Main Components	4
Versions	5
Dimensions	6
Unit Access	7
Installation Options	8
Installation Planning	10
Mounting Unit	11
Water Connections	13
Condensate Drain	15
Filling & Flushing	15
Commissioning	16
Electrical Connections	16
Ducting	17
Filters	19
Builders Duct	20
Grille Options	21
Standard Grilles	22
Built-In	22
Bulkhead	23
Maintenance.....	24
Product Options.....	24
Warranty	24

Main Components

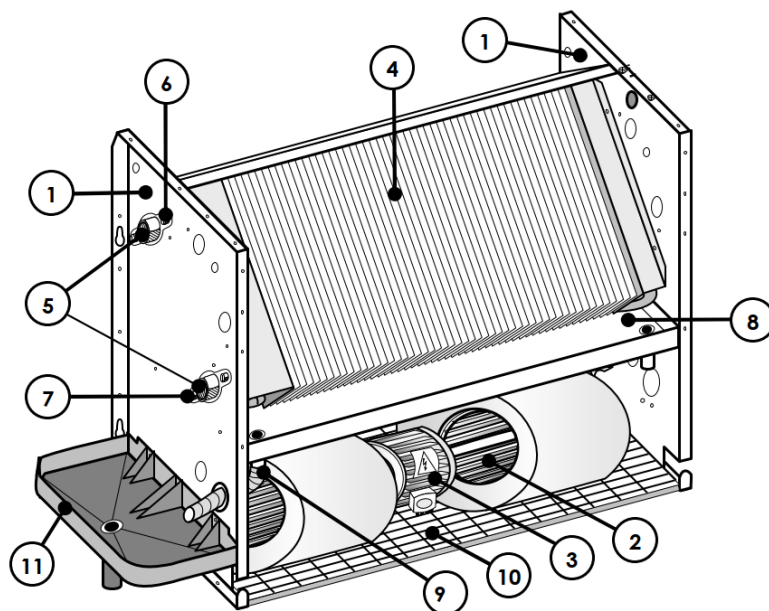

Standard Features:

1. Structure: Sturdy galvanized steel frame with pre-drilled holes for wall or ceiling mounting. Internal thermal and acoustic insulation.
2. Fan: Double-inlet centrifugal fan with forward-curved blades.
3. Motor: 230V single-phase motor directly coupled to the fan.
4. Coil: Heat exchange coil (one for 2-pipe systems, two for 4-pipe systems).
5. Plumbing: Connections for water coil.
6. Vent: Manual air vent valve
7. Drain: Manual water drain valve.
8. Drain pan: Drain pan with drain pipes (for vertical units).
9. Drain pipe: internal drain pipe.
10. Filter: G3-rated air filter.

Optional Accessories:

11. Auxiliary drain pan: drain pan for vertical versions.
12. Auxiliary Coil: an optional additional heating coil for 4 pipe applications (not shown)

Versions

The built-in fan coils are available in 4 versions.

Vertical version with bottom intake

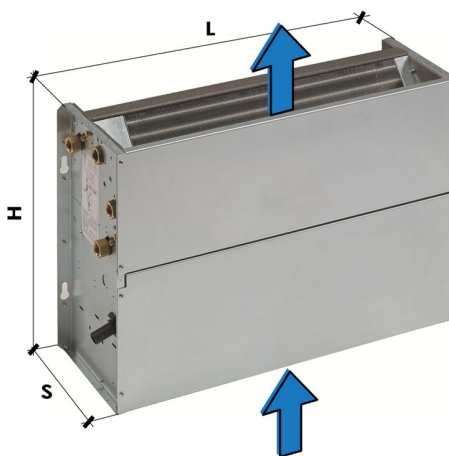

Horizontal version with rear instake *(stocked model)*

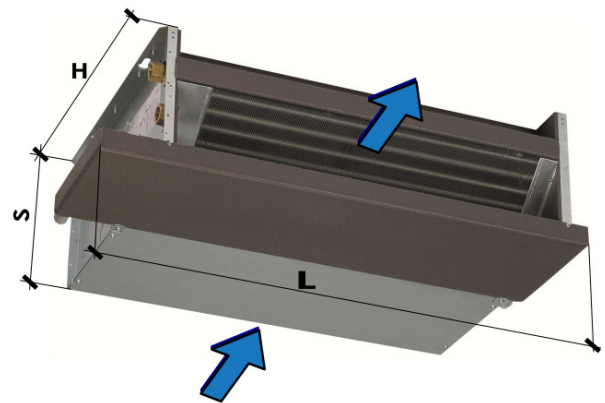

Vertical version with front intake

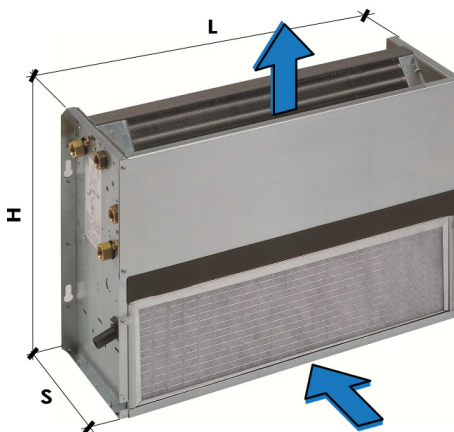

Horizontal version with bottom instake *(stocked model can be modified for this)*

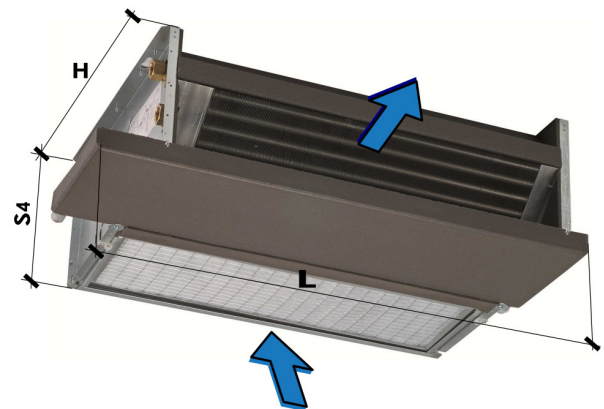

Through an installer modification a vertical rear intake unit can be converted to a vertical bottom intake unit. Refer to the Transformation instruction document.

Dimensions

Vertical

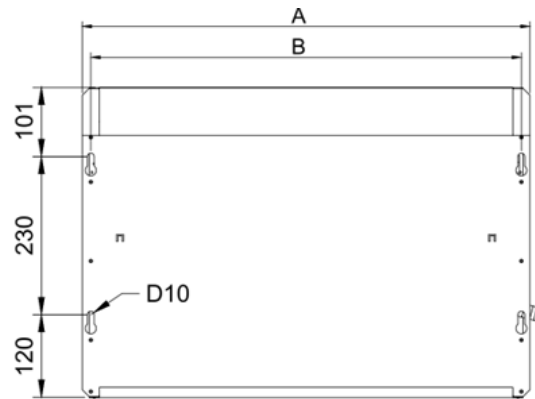
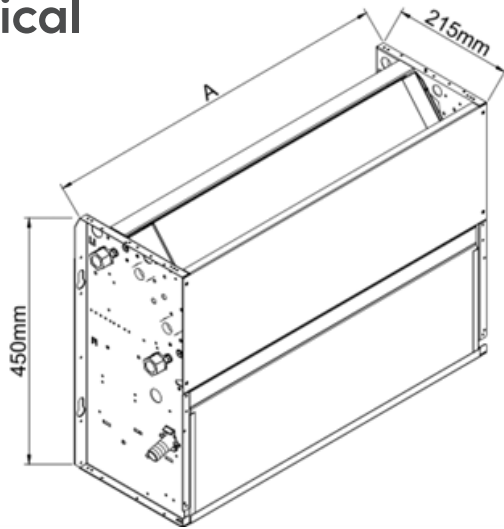

FC-VBI	1.5	2	2.5	3*	4	4.5	5	6*	6.5	8*
A (mm)	450	450	650	650	850	850	1050	1050	1250	1250
B (mm)	425	425	625	625	825	825	1025	1025	1225	1225
Weight (kg)	11	11.6	14	15	20	21	23.5	25	27.5	29

*Allow an additional 105mm for the optional Auxiliary drain pan

Horizontal

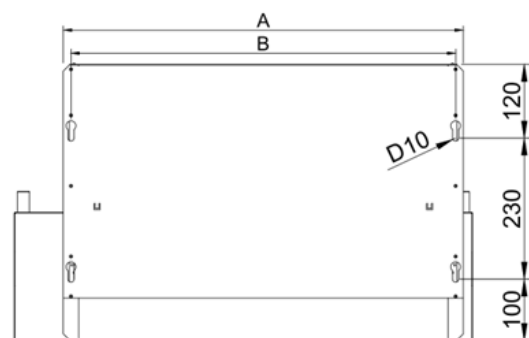
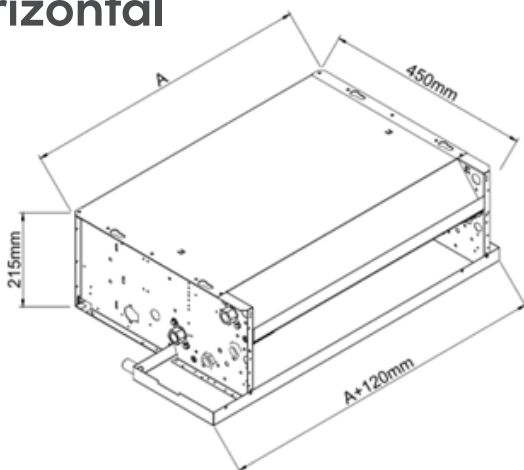

FC-HBI	1.5	2	2.5	3*	4	4.5	5	6*	6.5	8*
A** (mm)	430	430	630	630	830	830	1030	1030	1230	1230
B (mm)	425	425	625	625	825	825	1025	1025	1225	1225
Weight (kg)	11	11.6	14	15	20	21	23.5	25	27.5	29

*Units stocked by CHNZ – all others available via indent order

** Dimension A+ includes drain pan

Unit Access

Built-in units need to be accessible for future maintenance and unit replacement.

Depending on the installation scenario the access panel may be able to be made large enough for the entire unit to be accessed, installed, and removed through this opening and this is the preferred access panel size. The recommended access panel size is the unit width (Dim A from unit dimensions tables) + 200mm x 500mm.

In some situations, this is not possible and a smaller access panel for maintenance is all that can be provided, in this case any future unit replacement will require opening of the ceiling, wall, or joinery unit for total unit replacement. The minimum access panel size is 200mm x 500mm.

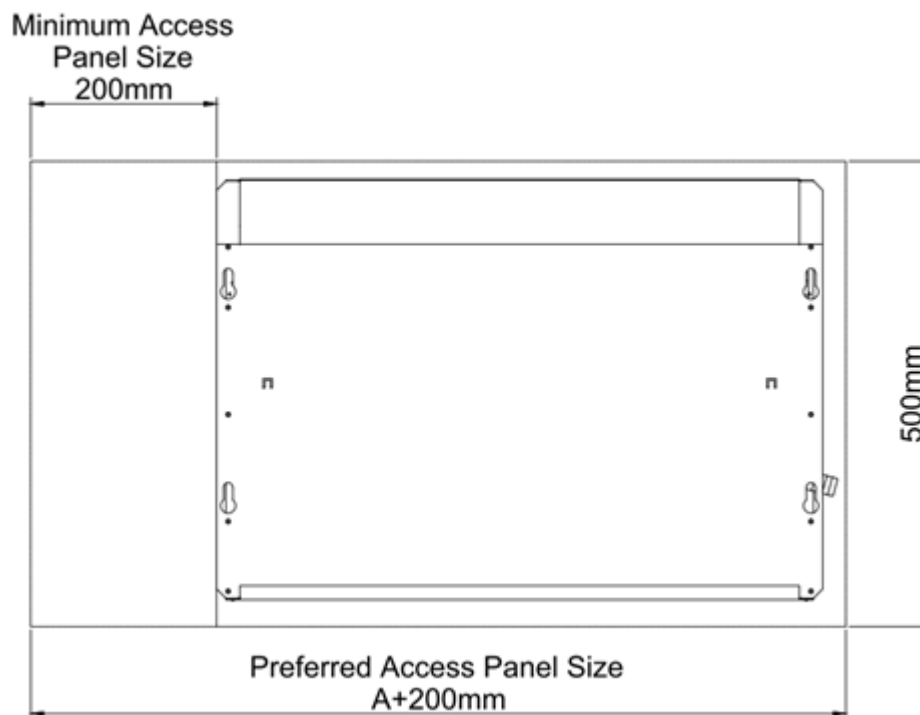

Installation Options

Built-in fan coils can be installed in several different installation scenarios to suit different project requirements. The units are concealed within the building structure or a joinery unit, some examples of common installation scenarios for built-in units are shown in the diagrams below, but there are many other possibilities with various ducting and grille options to achieve a fit for each project.

Common Built-In Scenarios:

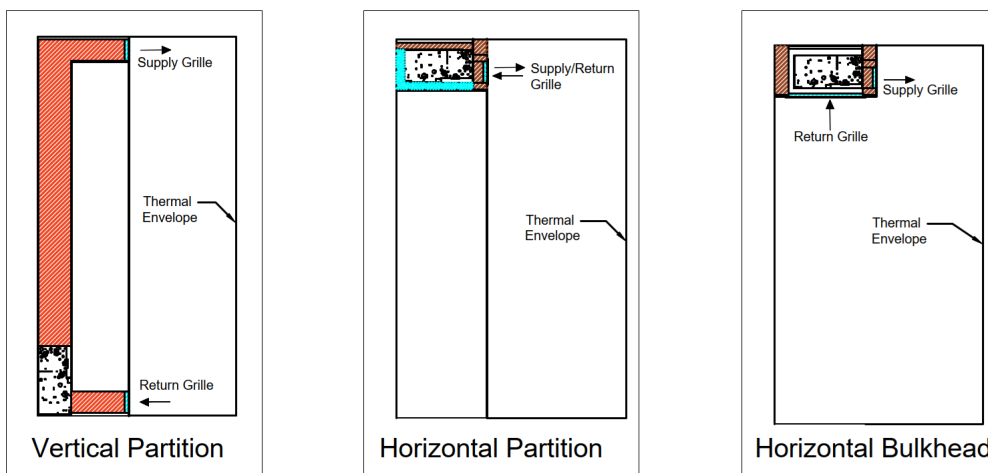

Where the return air path of the unit is within the thermal envelope of the home, ducting is not required, and a builder's duct can be used to achieve a ductless return. The unit is installed in this duct that is connected to the return grill and filter and then only the supply is ducted from the unit to the supply grille:

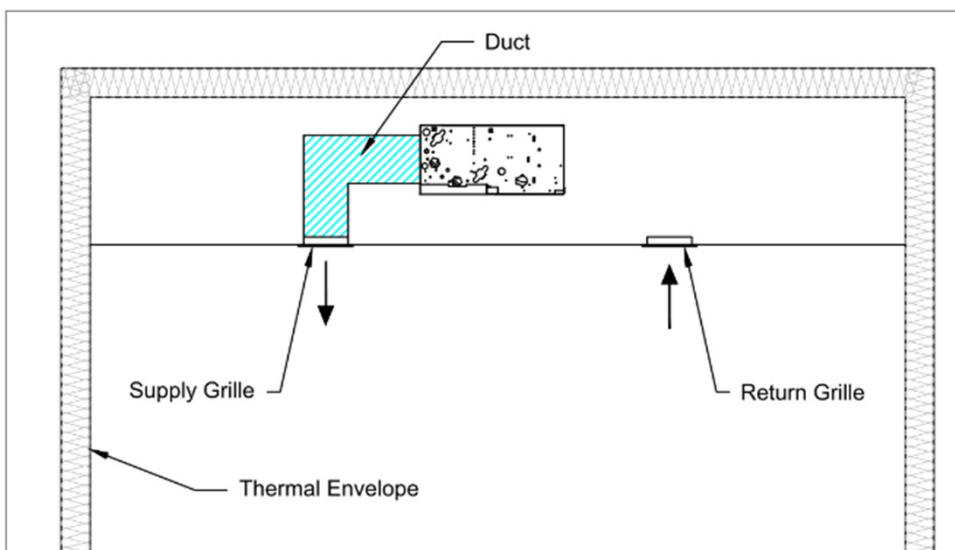

Where the units return needs to be run outside the thermal envelope the return must also be run in insulated duct:

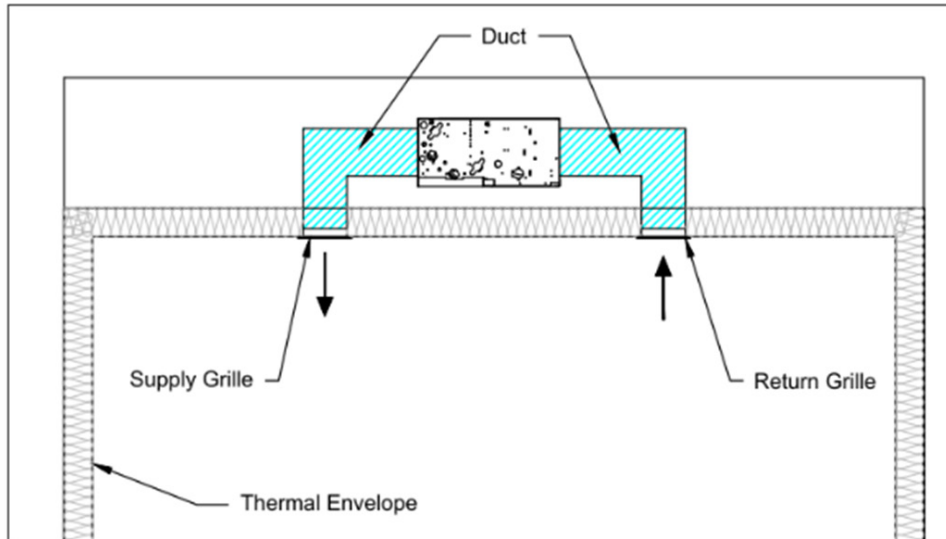

Installation Planning

When installing a built-in fan coil the planning of this installation is the most important aspect, these installations can involve many trades and ensuring the requirements for each are considered and coordinated will be key to a successful installation.

The list below outlines the steps and considerations for built-in fan coil installation planning;

1. **Unit Location:** The intended location of these units should be drawn on the plans, these drawings should show the location of supply and return grilles, any ducting, access panels, builder's ducts, condensate drains and pipe locations.
2. **Grille Types & Size:** The size and type of grille will generally be determined by the installation scenario and performance required. The size of the opening required for the grille needs to be coordinated with the builder to ensure this is practical with the structural framing requirements.
3. **Builders Duct:** Where the unit is required to be fitted in a builders duct the size and requirements of this need to be communicated to the builder as early as possible.
4. **Insulated Ducting:** Where units are required to be installed with ducting to the supply or return grilles ensure that the size of these will be able to fit through the structure. Complete a site visit once the structure is formed to measure up the duct size required and schedule in the manufacture of this.
5. **Access Panels:** Provision for future access for maintenance or replacement of the units is required. The size of these access panels needs to be provided to the builder so that this is factored into the construction.
6. **Insulated Pipes:** Insulated pipes that provide the heated and/or chilled water need to be planned and run from the heat source or plant to the unit's location ensuring that the pipe routes are as short as possible.
7. **Condensate Drains:** Drainage for the condensate pipe needs to be provided, for units that are not mounted on or next to an external wall drainage may need to be provided for in the floor at an early stage of the project (i.e. before the concrete slab is poured).
8. **Power & Controls:** Electrical supplies and control cable routes are needed from the switch board and/or the systems wiring centre, if these need to be run earlier in the project this should be planned out in advance.

Mounting Unit

Built-in fan coils are fitted into the structure once the building is enclosed and any builder's ducts have been created. Once this is completed the unit can be installed as per the following process;

1. **Mark Out:** Measure and mark out the unit, grill, access panel, pipe, drain, and electrical locations on the wall framing, linings, ceiling or floor. Check that the unit can be fitted in its intended configuration and access to all services is suitable.
2. **Fixings:** Add timber or similar into the building structure for the fixing of the fan coil, ducting, grilles, and pipe supports.
3. **Ducting and Grilles:** Test fit grilles and determine the ducting requirements from the unit to the grille. In some situations, the grille and unit can be installed without ducting using the timber framing as a duct between the unit and grille. Where the return grille is fitted to permit air flow into the builders duct the opening and sealing of this grille should be made and confirmed to be air tight at this point, the return grille will house the filter for the system and it is important that all of the air is run via this filter, use foam and sealing tape to ensure a snug fit of the return grille and seal any areas of potential air leakage in the builders duct.
4. **Seal Connection Faces:** Where the fan coil is installed with the grille and unit against each side of a timber opening an adhesive foam tape should be used on the inside surface of the timber for the fan coil unit to be installed against to create an airtight seal. The return edge of the grille should be confirmed that after wall lining this will create a tight seal against the framed opening. The surface of the framing that is used as a plenum from the fan coil outlet to the grille shall be painted with a suitable black paint or wrapped with a suitable tape to prevent this being visible through the grille.
5. **Mount Unit:** Using the fixing holes provided on the unit fix the directly to the mounting timbers or suspend on threaded rod. Ensure the unit is installed with a 3% slope to the back and drain side of the condensate tray. Pour a small amount of water into the tray and confirm that this will drain freely to the drain location.

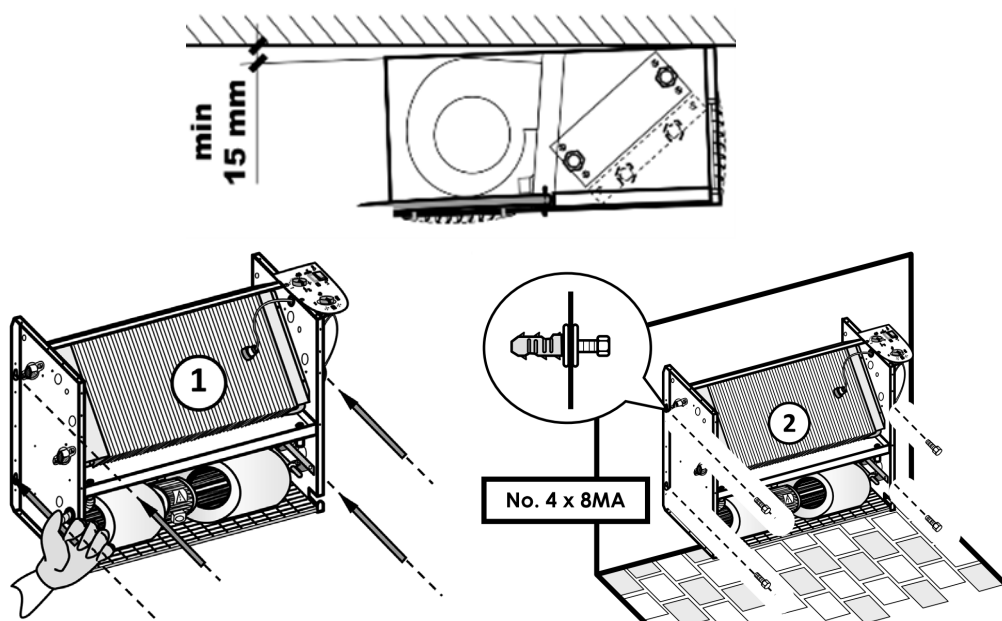

6. **Hydraulic Connections:** Make the required connections from the fan coil to the system pipe work ensuring to fit any valves, vents, and controls in the pipe work. Where these connections are outside of the condensate drip tray, they should be insulated with a minimum of 9mm insulation (see CHNZ Chilled Water Insulation Guide). Connect the units drain pan to the previously installed condensate drains, ensuring all connections are glued and fall is maintained, in some situations it is recommended to install a trap in the condensate line (refer to CHNZ condensate guide).
7. **Electrical Connections:** The required cables from the plant, switchboard, and controller should have been run at an earlier stage and can now be connected to the fan coil unit and any control valves fitted on the supply pipe to the unit. Make these connections now ensuring they are secure and correct. Some controllers require a probe to be fitted to the supply pipe of the unit to prevent the fan operating until the water is suitably heated or cooled – wrap this probe onto the supply pipe of the unit onto a metal fitting and add a layer of insulating tape around this.
8. **Testing:** Once the unit is fitted the installation should be tested, where possible the controller should be fitted and unit powered, with the functions of the fan coil confirmed (speed control, mode check). The pipe connections should be pressure tested to ensure that they are watertight, and water should be poured into the condensate tray to confirm that the condensate drain is well sealed and free flowing.
9. **Enclose Unit:** Once the unit is fitted and tested the remaining structure can be built around the unit to enclose this into the wall, ceiling, or joinery unit. Ensure the required access openings will be provided as per the earlier unit access section.

Water Connections

The Built-In fan coils are supplied with ½" female hydraulic flow and return connections, the recommended valves and fittings to fit at each fan coil are:

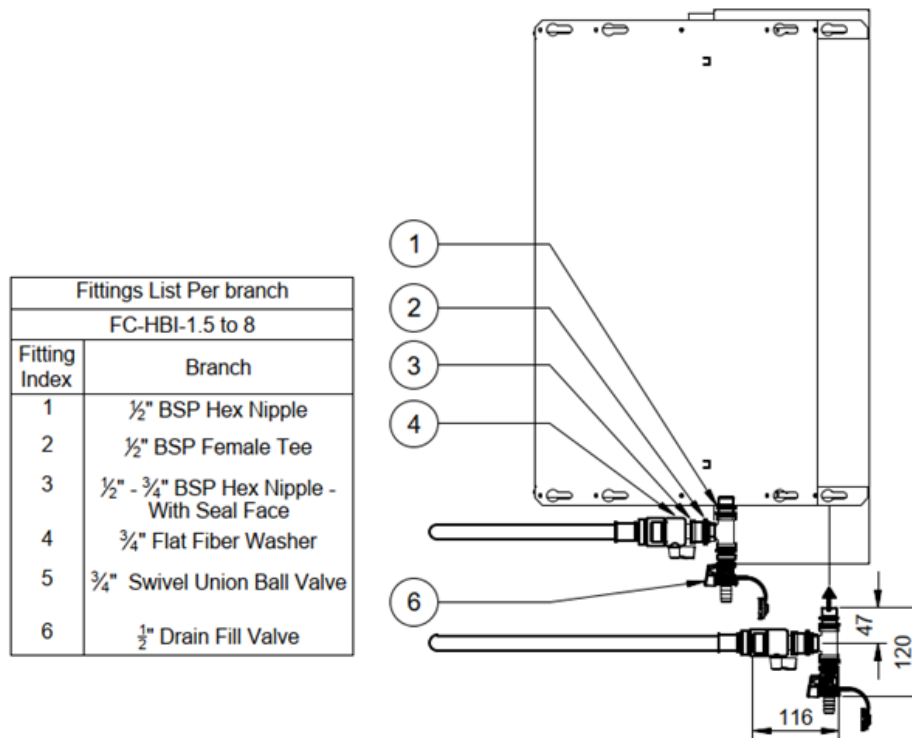

These fittings and valves are available from CHNZ as a fitting kit – FCFITHBI:



Quantity	Description	Product Code
2	Brass ½" BSP Hex Nipple - Plain	HMHBHN15
2	Brass ¾" - ½" BSP Reducing hex nipple – With seal face	HMHBRHNS2015
2	Brass ½" BSP Female tee	HMHBFT15
2	¾" Swivel union ball valve	BXCKHT
2	½" Drain/fill tap	DRAINTAP15

These fittings and valves allow for easy installation, commissioning, and servicing of the fan coil units.

- The fan coils supply and return coil connections include drain valves in each fitting, but these are limited in their ability to allow flushing/venting of the fan coil. For this reason, it is recommended to fit drain/vent taps into the pipe work for each unit to permit easy filling, flushing, and venting of the fan coil.
- Where the control of the flow to the fan coil is managed at the fan coil a 2-port motorized valve should also be fitted at the fan coil unit, the recommended valve for this is the Danfoss 20mm zone valve and actuator. Refer to the system schematic to confirm if this is required.
- The minimum pipe size that is permitted to be run to these units is 20mm ID, (25mm OD Multitubo), the sizing of the pipe will be dependent on the system design and the schematic should be reviewed to confirm the pipe sizing.
- All pipe work, valves, and fittings that are outside the catchment area of the fan coils drip tray must be insulated with minimum 9mm thick insulation but 13mm thick insulation should be used where possible.
- Pipe work must be suitably supported and not allowed to 'rest' on the fan coil fittings.

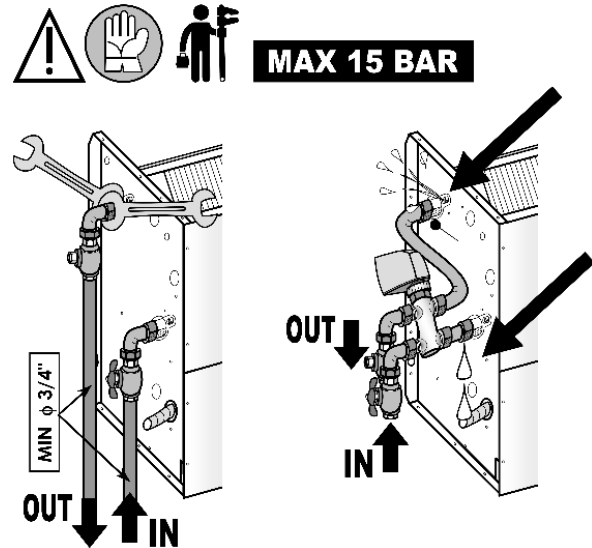

Condensate Drain

The Built-In fan coils include drain trays to collect the condensate that is produced on the heat exchanger when operating in cooling mode. The condensate needs to be drained away to a suitable drain location.

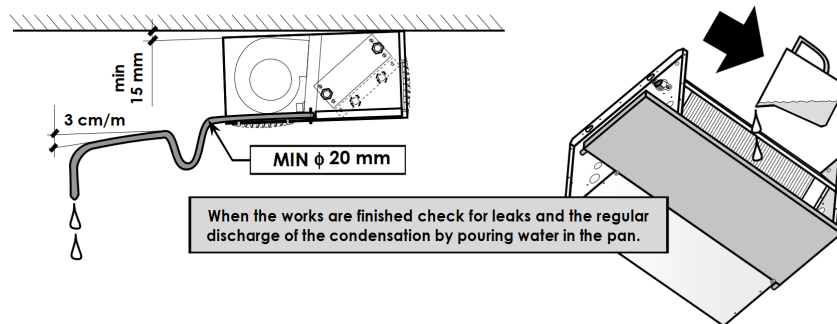

- The CHNZ Condensate Drainage Guide provides general advice for planning and installing fan coil condensate drains and should be referred to before installing any fan coil systems.
- The Built-In fan coils should be installed with an intentional slope back to the drain spigot.
- The Built-In fan coils are supplied with a 20mm stub for connecting the condensate hose to and it is recommended that 20mm pressure pipe is used for the condensate pipe connection to the fan coil with a rubber boot used to connect the pipe to the unit.
- The condensate pipe should be installed with at least 3% fall along its entire length to a suitable drain location, the installation of a trap/siphon in the drainpipe is recommended and is mandatory for the vertical units.
- The condensate should be run in its own drain to outside or where combined into an internal wastewater drain this should be done via an open trap to ensure no odours can be drawn into the fan coil.
- The condensate drain should be tested to confirm that there are no leaks before the unit/wall is closed in.

Filling & Flushing

The following procedure is recommended for filling and flushing of the Built-In fan coils:

1. Fill and flush the system with all valves on the fan coil closed.
2. Open the fan coil flow pipe isolation valve and then open the return port vent/valve.
3. Once water is present at the return vent close this and open the return isolation valve.
4. Run the flushing cart/system pumps to remove all air from the unit.
5. Once the fan coil is flushed and free of air isolate this fan coil from the system until all other system components are flushed.

Commissioning

The following procedure is recommended for commissioning of the Built-In fan coils:

1. Once the system is filled, flushed, and operating - functional tests and balancing of the fan coil should be completed.
2. The fan coils water supply may include a balancing valve/flow meter. Set the valve to the designed setting/flow rate and record the setting/flow rate achieved.
3. Using the fan coils controller test all of the fan coils functions, this will include all or some of the following;
 - Fan operation prevented until water temperature at controller probe in correct range, test for both heating and cooling.
 - Fan coil operation (fan run and valve open) in both heating and cooling mode.
 - Air flow direction and quantity correct through adjustments of grille.
 - Filter installed correctly and all return air passed through filter element with no gaps.
4. Test the fan coils air flow is sufficient and confirm there is no air leakage around the outside of grilles and builders' ducts/joinery.

Electrical Connections

The Built-In fan coils include a terminal strip for making connections at the unit, when making the electrical connections consider the following.

- **Wiring Diagram:** Carry out electrical connections according to the included wiring diagram. Diagrams may be updated, so refer to the one provided on the unit.
- **Connection & Switch:** Connect the unit to a suitable permanently connected and locally switched power supply.
- **Terminals:** connect the unit to the power supply and system following the terminal guide below:
 - **4:** Signal ground from 0-10V controller.
 - **3:** 0-10V DC fan speed input.
 - **2:** Neutral.
 - **1:** 230V Live supply.
 - **E:** Earth connection.
- **Enclosure:** Where access to these units is likely by the occupants, it is recommended to fit off these connections inside an electrical enclosure that is fitted off to the units housing over the factory terminal strip.
- **Compliance:** All wiring and connections must be made in compliance with AS/NZS 3000:2000.

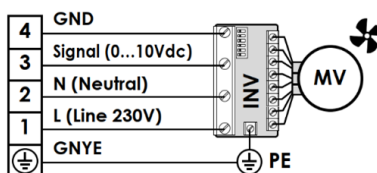

Ducting

For correct operation and performance of a built-in fan coil the transition from the fan coil to supply and return grilles needs to be well planned and executed.

The conditioned supply air must be ducted to the supply grille, and this can be achieved in a number of ways depending on the installation scenario:

Fabricated Ducting: Insulated ducting made with sheet metal or rigid insulation panelling can be used to duct the outlet of the fan coil to a supply grille or supply grilles, in some situations a plenum box can be made to fit onto the unit that will then allow the ducted supply connections to be reticulated in flexible ducting.

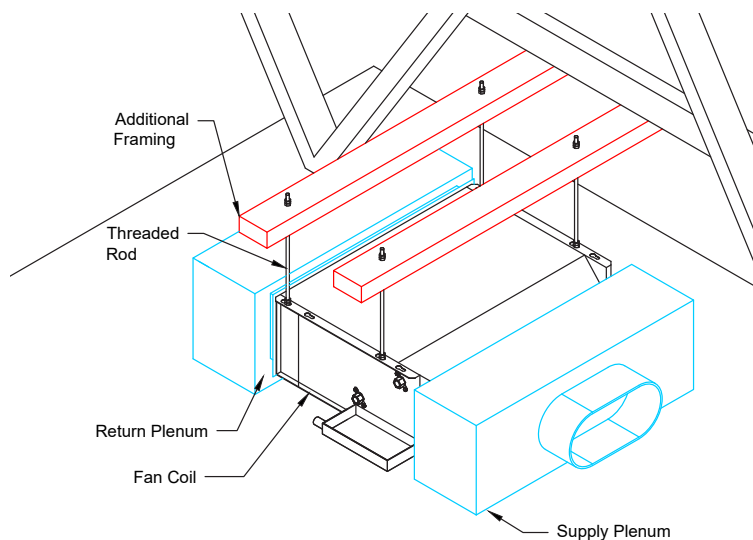

Ducting Through Wall: Where the fan coil and grille are installed on either side of a timber wall, creating an opening in the framing to act as the transition from the supply of the fan coil to the grille is an acceptable and cost-effective solution. Each side of the timber should have a suitable foam tape applied to create an airtight seal to the unit and grille and the internal surfaces of the timber duct painted or wrapped black to prevent this being visible through the grille.

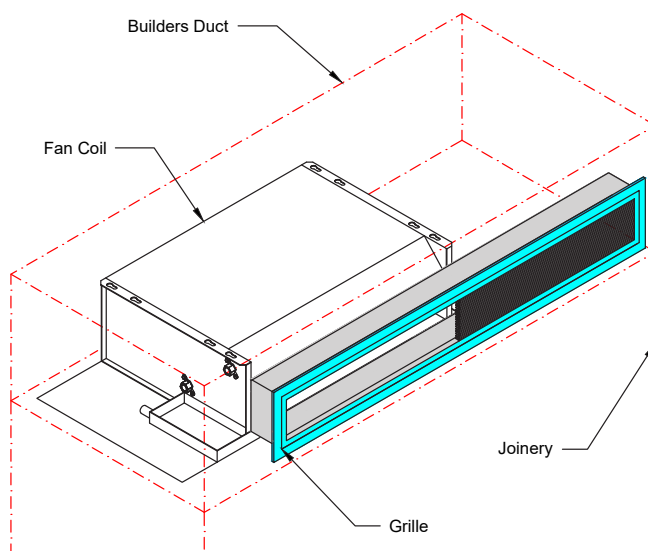

Joinery Ducting: Where the fan coil is installed inside a joinery unit the joinery manufacturer can create supply and return duct paths within the joinery units, the supply air should be run through insulated ducting that is fitted within the joinery.

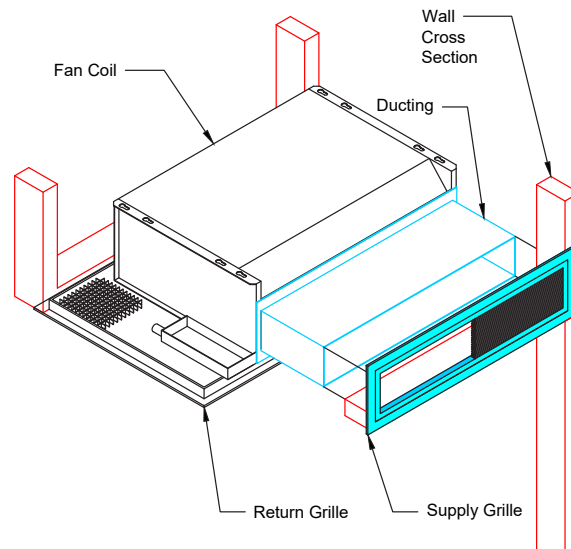

Filters

All air that enters a fan coil needs to be filtered, on board or return grille filters must be used to ensure any particles in the air do not enter the fan coil as these would collect on and block the heat exchanger. The filters also provide the added benefit of collecting and removing particles and allergens from the homes air to provide a healthier internal environment.

The filters need to be accessible and at least annually need to be cleaned by the service agent. Correct installation of the filter element is critical to ensure no unfiltered air is allowed to enter the fan coil unit so it is not recommended that the filter is removed by the homeowner, however if required external vacuuming of the filter grille monthly is sufficient between annual filter cleaning.

The filters supplied with the units are G3 type filters which provide sufficient filtration for normal residential and commercial applications, if a higher level of filtration is needed then then filters with a higher filter grade can be custom made.

The return air to the fan coil does not need to be run in ducting when run inside the thermal envelope of the building. The return air does however need to be run through a filter to ensure air contaminants in the air do not enter and block the fan coils heat exchanger. The filtering of the fan coils return air can be achieved in one of two ways:

On-Board Filter: The fan coils are supplied with an integrated G3 rated filter, the on-board filter is suitable to use if access to this for removal, cleaning, and replacement is achieved easily through a suitable access hatch – this should at least be the size of the recommended access panel size.

Return Grill Filters: Where access to the unit will be more difficult or limited, the fan coils should be installed with a ducted return path (fabricated sheet metal ducting or builders' duct) to ensure all return air to the fan coil runs through the return grille/s. The return grille/s should be fitted with removable filter elements to ensure only cleaned air is allowed to enter to return ducting. In this scenario the units on-board filter element can be removed to increase air flow.

Builders Duct

In a builder's duct, the builder forms an enclosure for the fan coil to be installed within created from wall lining materials (GIB) or timber (MDF, Plywood), all seams should be sealed with tape or a suitable sealant to ensure this duct is airtight.

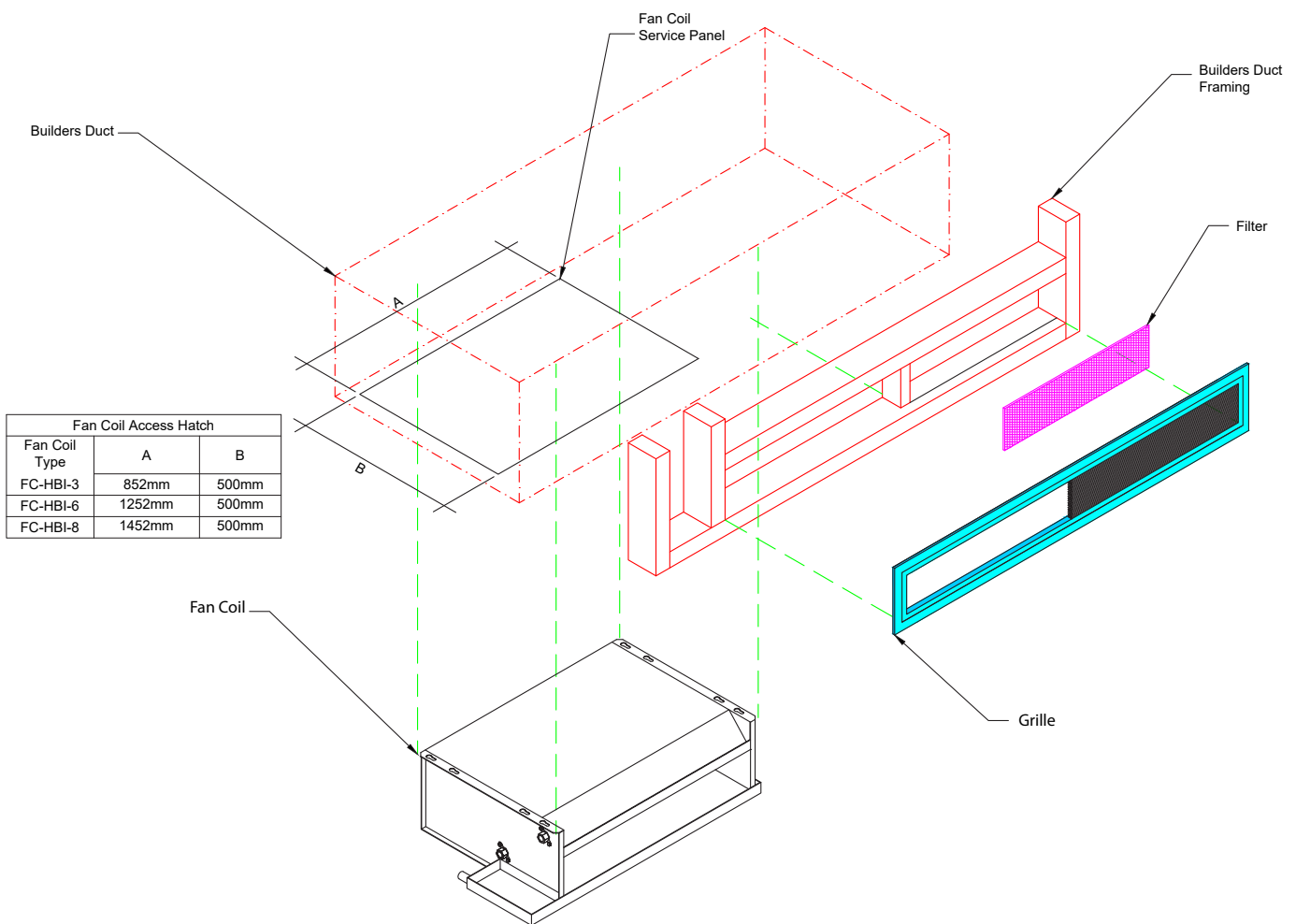

The only openings in this builder's duct should be to permit the supply and return grilles being installed and these should be installed with an airtight seal with foam tape or similar achieving total control of the return air path to and from the fan coil. If access to the fan coil within this builder's duct will be difficult the return grilles should include filters ensuring all air that enters this is filtered before entering the fan coil.

An access hatch into the builder's duct for fan coil maintenance is also formed and along with the supply and return grill connections into the builders duct these connections needs to be tightly sealed with foam tape or similar on sealing faces.

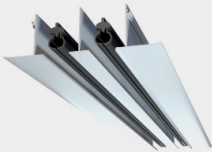

Grille Options

Built-in fan coils are typically installed with linear type grilles installed in walls, ceilings, or joinery units. Many grille options are available to suit a homes aesthetic requirement and some of these can include integrated filter elements. Some example images of the grille options for supply and return filters are shown in the table below:

Description	Example	Supply	Return
LD-600/1200 Linear Bar Grille		✓	✓
Slot Diffuser		✓	✓
Egg Crate Grille		✗	✓

When fan coils are installed within joinery units the joinery manufacturer may want to machine openings within the joinery units, the size of these openings should be specified to suit the air flow requirements of the fan coils. An example of this type of joinery opening is shown in the image to the right.

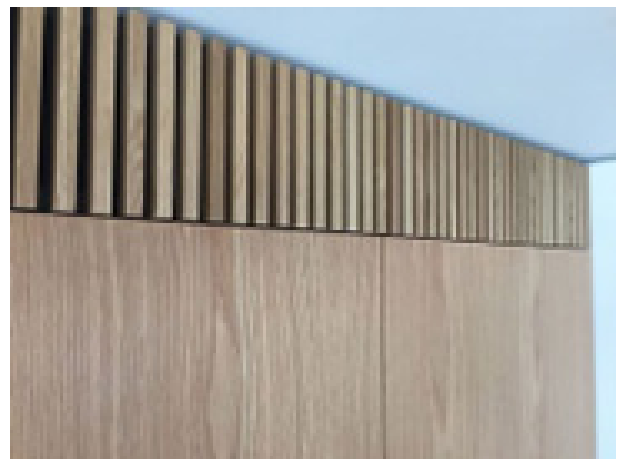

Standard Grilles

For the 3 stocked sizes of the Built-In fan coils CHNZ also have standard grill options available. The standard grill options allow either a built-in or bulkhead type installation;

Built-In

The Built-In grille option uses a single bar grille to act as both the supply and return grille, a section of the grille includes a removable filter and this should be partitioned from the supply section in the grille framing. The standard grille sizes for this option are shown in the table below:

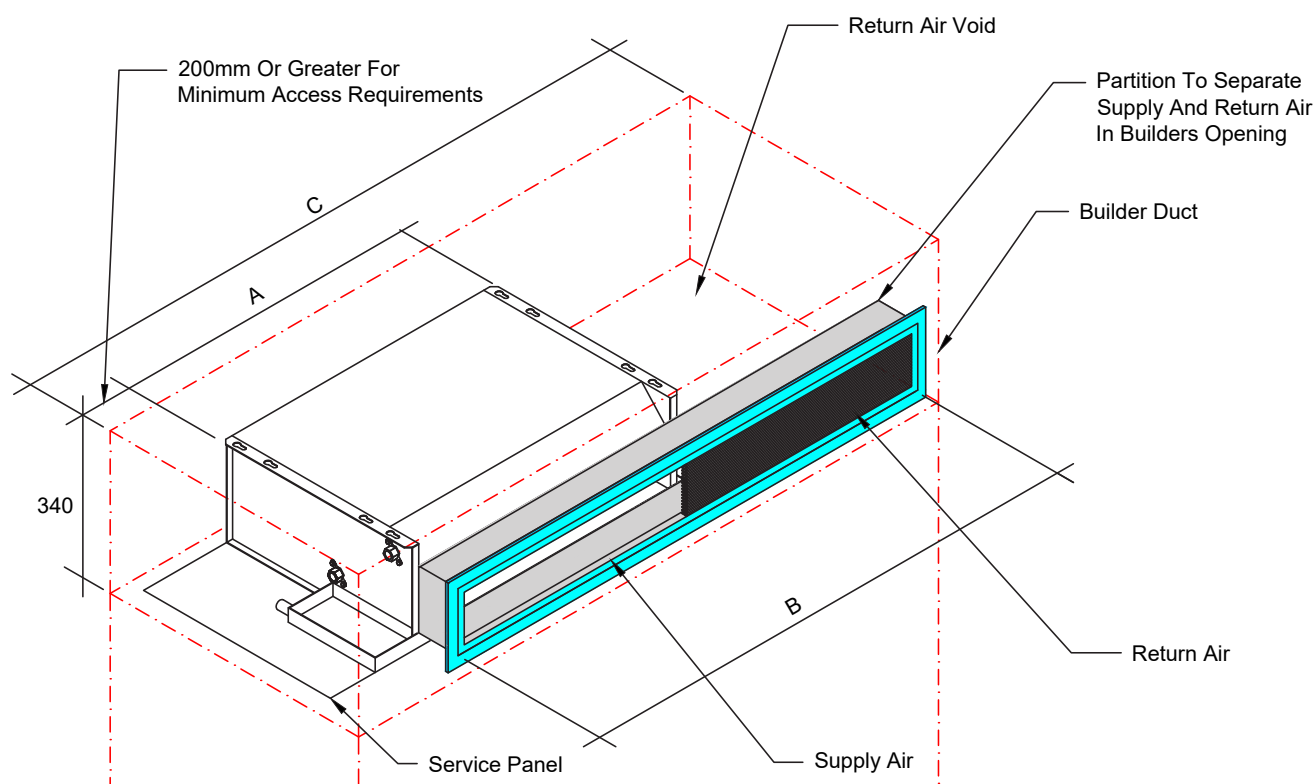

Fan Coil Model	Grille Size mm (B)	Return Section Width mm	Product Code
FC-HBI-3	140 x 1110	478	FCALD600-RC-EN1110x140
FC-HBI-6	140 x 1890	768	FCALD600-RC-EN1890x140
FC-HBI-8	140 x 2145	913	FCALD600-RC-EN2145x140

Bulk Head

The Bulkhead grille option uses a bar grille to act as the supply grille and an egg crate grille to act as the return grille, the egg crate return grill also acts as the access panel for the unit. The standard grille sizes for this option are shown in the table below:

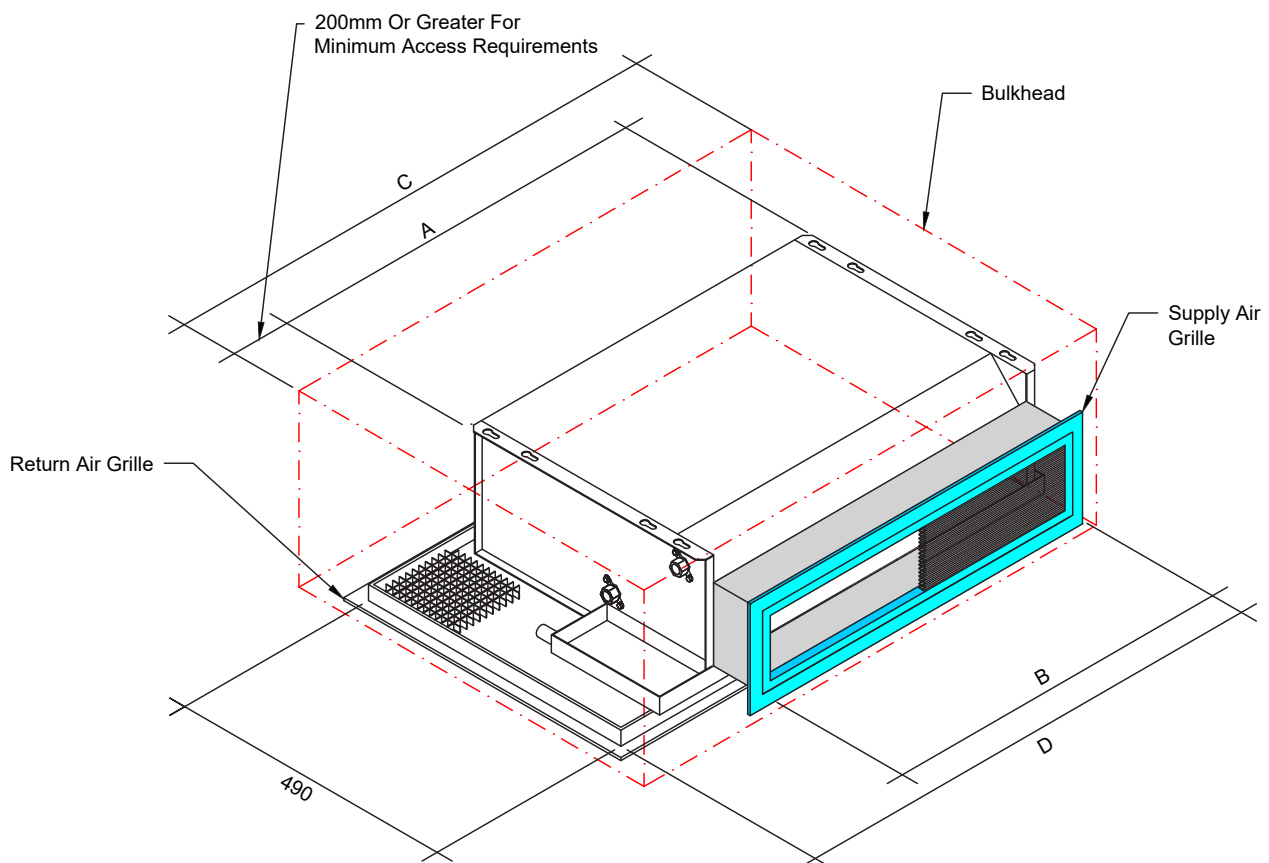

Fan Coil Model	Grille Size Width mm (B)	Product Code	Return Grille mm (D)	Product Code
FC-HBI-3	140 x 602	FCALD600-RC-EN602x140	835	FCAEC-125FR-B-EN852x490
FC-HBI-6	140 x 1002	FCALD600-RC-EN1002x140	1235	FCAEC-125FR-B-EN1252x490
FC-HBI-8	140 x 1202	FCALD600-RC-EN1202x140	1435	FCAEC-125FR-B-EN1452x490

Where the grille sizes required for a unit need to be different from the standard sizes included in the above tables, please contact CHNZ to confirm suitability and pricing.

Maintenance

The following table lists the recommended maintenance tasks along with the recommended frequency:

System Aspect	Maintenance Overview	Who	Frequency
Pipe Insulation	Check joints are sealed and all aspects insulated	Service Agent	Annually
Water Damage	Check for signs of water damage from leaks or drips	Service Agent	Annually
Surface Cooling Condensation	Check that surface cooling systems have not formed condensation and controller settings	Service Agent	Annually
Air Filters	Surface clean of return grilles	User	Monthly (during use of fan coils)
Air Filters	Remove, inspect, and clean or replace air filters	Service Agent	Annually
Condensate Drains	Check condensate drains run freely	Service Agent	Annually
Fans	Check fans operate and run freely	Service Agent	Annually
General Condition	Check unit fixings and inspect unit cleanliness	Service Agent	Annually

Product Options

The Built-In fan coils stocked by CHNZ are ordered in a standard specification for horizontal installation with the brushless fan, however for project specific requirements other product options are available on special order. Some of the product options that may be suitable for project specific requirements are;

- 3 speed AC fan.
- Vertical orientation with auxiliary condensate tray.
- Auxiliary heating coil for 4 pipe systems.
- Electrical heating elements.

For more information and pricing on these options please contact your local sales representative.

Warranty

The Built-In fan coils are supplied as per Central Heating New Zealand's standard [Warranty](#) and [Terms & Conditions](#). For the warranty period refer to the 'Fancoil and Kickspace heaters' section.

New Zealand's Experts

The combination of our skills, products, experience and people, make us New Zealand's experts in the central heating industry. We take pride in supplying the right heating system or products for our customers' specific functionality and budget requirements so that at the end of every project, both our customers and their clients are delighted—and warm.

Central Heating New Zealand: the experts in hydronic central heating and cooling products, systems and design.

Keep up to date with the latest products and promotions on our mobile-friendly website trade.centralheating.co.nz.

We have tailored our website to make it easier for you to search products, checkout faster, store multiple shipping addresses and view your past orders.



Find out more at centralheating.co.nz

3 Enterprise Avenue, Islington, Christchurch, 8042

info@centralheating.co.nz

0800 357 1233

