

Data sheet

Automatic bypass control AVDO

Application



AVDO is a self-acting constant flow control primarily used either to maintain minimum flow rates through e.g. a low-capacity gas boiler or to control the differential pressure in a central heating system.

- is dimensioned for pressure stage PN 10, max. 120 °C
- DN 15 and DN 20
- operates without impulse tubes

AVDO:

- opens on rising differential pressure
- has a setting range of 0.05 - 0.5 bar

On delivery valve housing is fit onto AVDO with one of the following fittings: internal socket thread, internal socket thread/nipple or external thread for compression fittings.

Princip

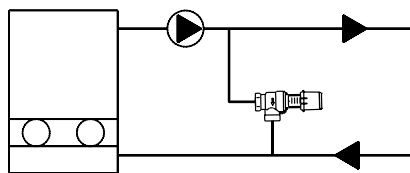

Low-capacity gas boiler where maintenance of a min. flow is required

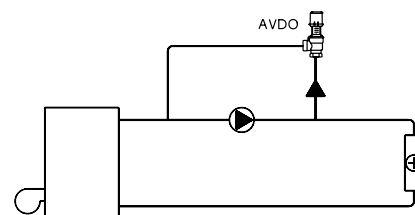

Differential pressure control

Ordering

Type	Setting range, bar	Connection		Code no.
		Inlet	Outlet	
AVDO 15	0.05 - 0.5	R _p 1/2 ¹⁾		R _p 1/2 ¹⁾
AVDO 20		R _p 3/4 ¹⁾		R _p 3/4 ¹⁾
AVDO 25		R _p 1 ¹⁾		R _p 1 ¹⁾
AVDO 15	0.05 - 0.5	R _p 1/2 ¹⁾		R 1/2 ¹⁾
AVDO 20		R _p 3/4 ¹⁾		R 3/4 ¹⁾
AVDO 25		R _p 1 ¹⁾		R 1 ¹⁾
AVDO 15	0.05 - 0.5	G 3/4 A ²⁾		G 3/4 A ²⁾
AVDO 20		G 1 A ²⁾		G 1 A ²⁾
AVDO 25		G 1 1/4 A ²⁾		G 1 1/4 A ²⁾
AVDO 15	0.05 - 0.5	R _p 1/2 ¹⁾		R 1/2 ¹⁾
AVDO 20		R _p 3/4 ¹⁾		R 3/4 ¹⁾
AVDO 25		R _p 1 ¹⁾		R 1 ¹⁾

¹⁾ According to ISO 7/1

²⁾ According to ISO 228/1

Accessories (supplied in boxes of 10)

Copper tube fittings		Code no.
AVDO 15	Ø 16 x 1	13U0131
	Ø 18 x 1	13U0132
AVDO 20	Ø 18 x 1	13U0134
	Ø 22 x 1	13U0135
AVDO 25	Ø 28 x 1	13U0140

Technical data

Setting range.....0.05 - 0.5 bar
 Max. differential pressure0.5 bar
 Operation pressurePN 10

Max. flow temperature..... 120 °C
 Max. leakage at closed valve50 l/h

Capacity

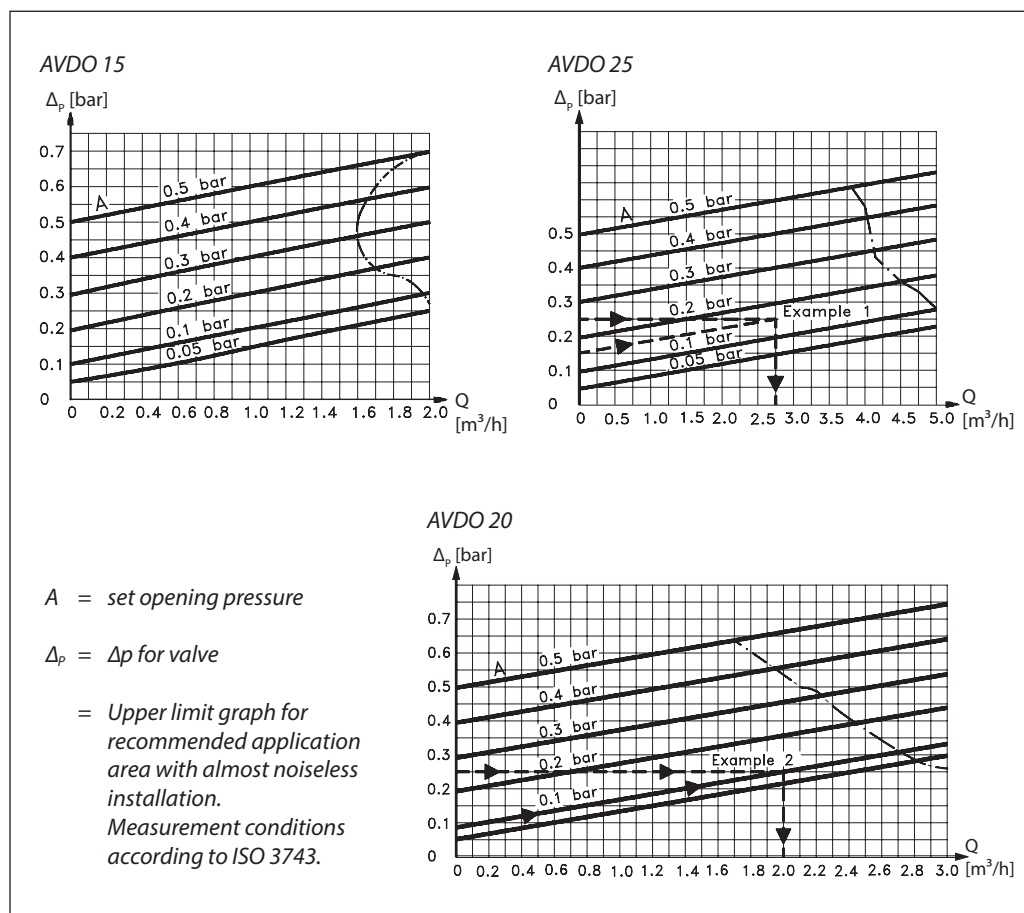

Design

Materials

1. Setting handle	Pom-plast
2. Base	Ms 58
3. Spring guide	PPS plastic
4. Spring	Stainless steel
5. Valve cone	PPS plastic
6. Valve body	Ms 58, hot-pressed
7. Setting pin	Stainless steel
O-rings	EPDM

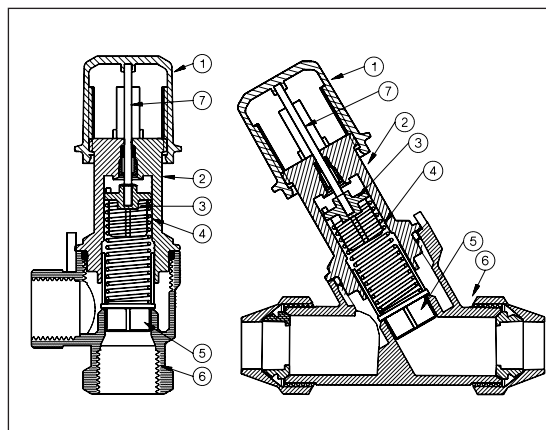

Installation

The valve body must be mounted with flow in direction of the cast-in arrow.

Setting

The control is set by turning the setting dial. AVDO has a setting scale on which the opening pressure in bar or mwg can be directly read. The differential pressures stated for a given setting are indicative.

The scale gives the differential pressure across the AVDO when it just begins to open.

Sizing

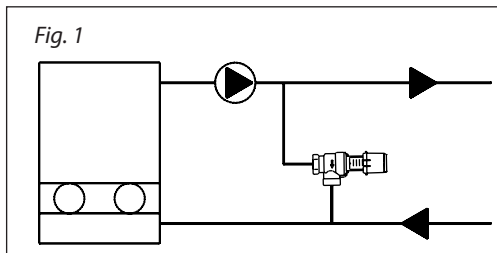

Example 1:
Bypass control across heating system

Given:

- System, see fig. 1.
- Insignificant pressure loss in pipe from boiler to bypass.
- Pump characteristic, see fig. 2.
- 0.15 bar system differential pressure at max. system load.

Required:

- Bypass circulation beginning at 0.15 bar pump pressure.
- Min. 2.0 m³/h boiler circulation.

Seek:

- A constant flow control that opens concurrently with falling load across the system (closing radiator thermostats).
- A constant flow control that ensures min. 2.0 m³/h boiler circulation at min. system load.

Solution:

- A 2.0 m³/h flow corresponds to a 0.25 bar pump pressure. On closing radiator thermostats AVDO is to ensure min. 2.0 m³/h circulation at 0.25 bar differential pressure across AVDO. Choose AVDO 25 that provides 2.75 m³/h at 0.25 bar differential pressure across valve. Set AVDO on 0.15 bar required opening pressure.

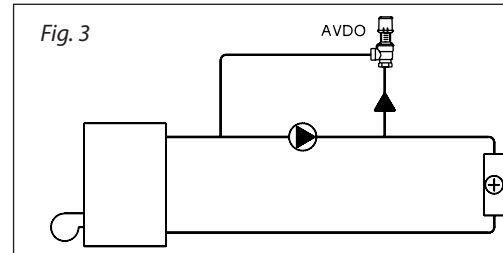

Example 2:
Bypass control across circulation pump

Given:

- System, see fig. 3.
- Pump characteristic, see fig. 4.

Required:

- Bypass circulation beginning at 0.1 bar pump pressure.
- Max. system differential pressure at closed radiator thermostats must be limited to 0.25 bar.

Seek:

- A constant flow control that opens concurrently with falling load across the system (closing radiator thermostats).
- A constant flow control that ensures max. system differential pressure not exceeding 0.25 bar at min. system load.

Solution:

- The max. permissible differential pressure 0.25 bar across system corresponds to a 1.8 m³/h water volume (fig. 4). At min. load AVDO must ensure 1.8 m³/h pump bypass circulation. In this example AVDO 20 must be used - see "Capacity". - As circulation is not to begin before differential pressure across system has exceeded 0.1 bar, AVDO is set on 0.1 bar - see "Setting".

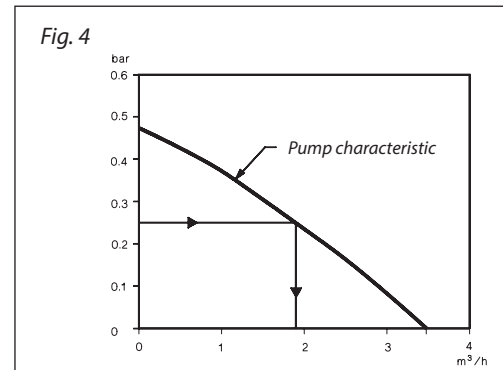
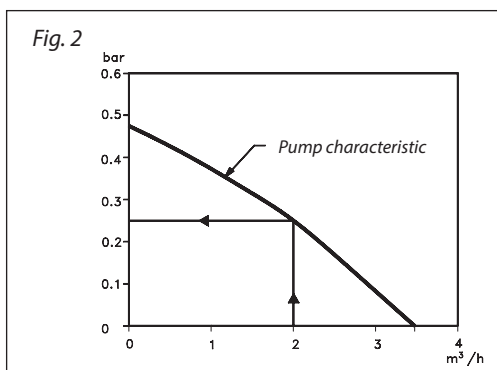

Dimensions

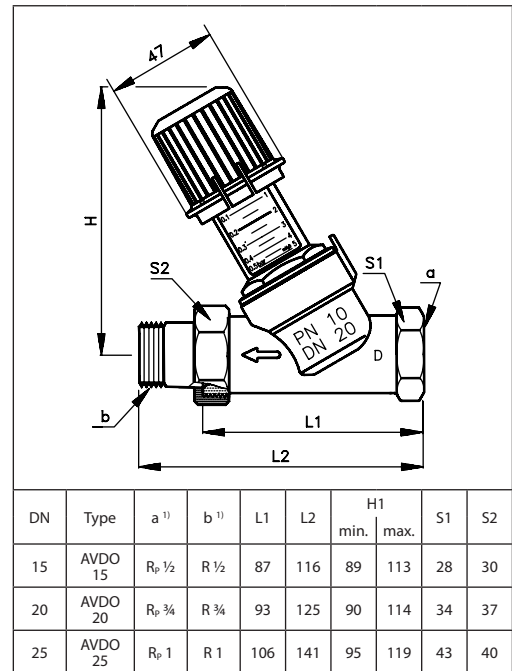
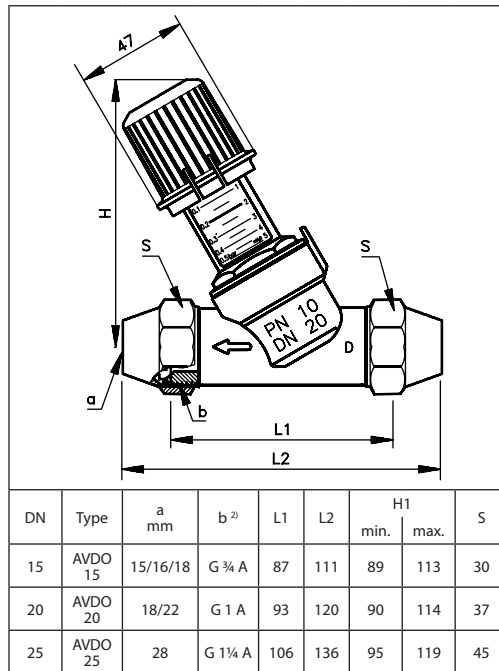
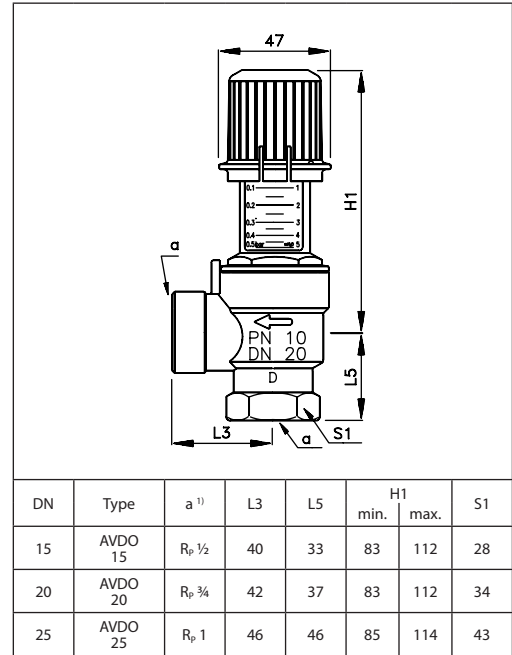
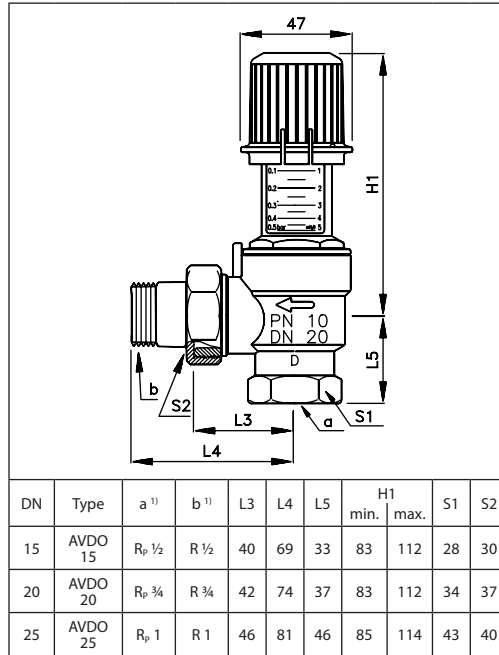

¹⁾ According to ISO 7/1

²⁾ According to ISO 228/1