

Diesel Tank Installation Advice

For JSM 480 Litre & 980 Litre Diesel Tanks

This guide provides advice on how to install your JSM diesel tank. Much of this detail is appropriate by most jurisdictions, however the installer is responsible for ensuring local authority requirements are met.

The topics covered by this document are:

1	Tank design & detail	page 1
2	To bund or not to bund	page 2
3	Stability, support and seismic restraint	page 3
4	Location and separation distances	page 3
5	Approval process	page 4
6	Tank Accessories	page 5

Tank design & detail

The tank has been designed and manufactured in compliance with AS 1692: 2006.

Each tank has the following features:

- ① 50NB Filling port centrally located on the top
- ② 10NB Outlet port on the bottom
- ③ 40NB Plugged port on top for additional features
- ④ Restraint tabs
- ⑤ Feet with bolt holes

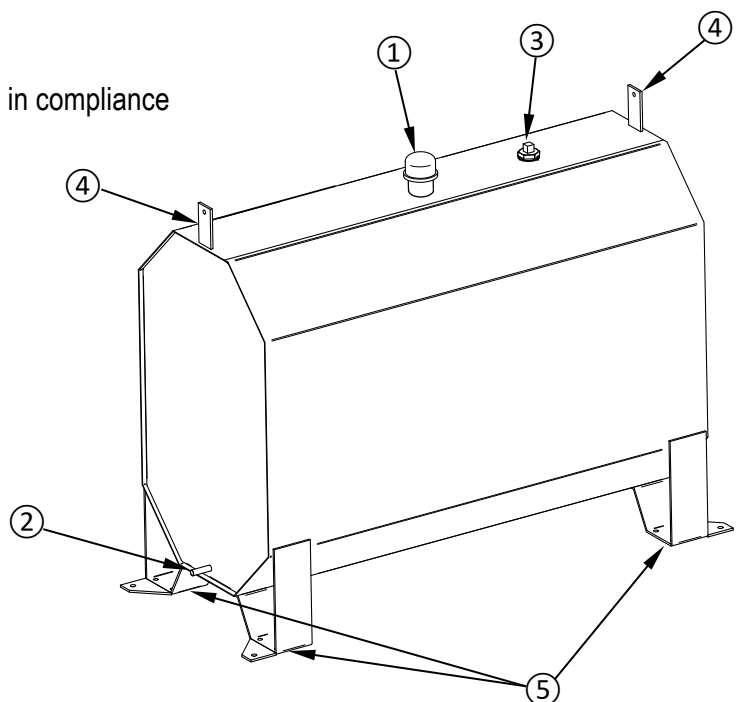

Tank sizes

Volume	Tank Height (no leg extensions)	Tank Width	Tank Length	Dry Weight	Wet Weight
480 L	1026 mm	548 mm	1340 mm	70 kg	525 kg
980 L	1319 mm	618 mm	1756 mm	165 kg	995 kg

Volume	Bund Height (with cover)	Bund Width	Bund Length	Dry Weight	Wet Weight
480 L	955 mm	630 mm	1480 mm	38 kg	N/A
980 L	1255 mm	685 mm	1955 mm	55 kg	N/A

The most common requirement for installation of the tanks is that they are installed compliant to AS 1691:1985

Bund or no Bund

A bund, in simple terms, is a secondary containment surrounding the tank. If the tank leaks, the leak will be contained by the bund. Our bunds are manufactured from galvanized steel and include a cover that prevents water filling the lower bund that surrounds the tank. It's not very common for the tank to be damaged or punctured, but sometimes spills occur when filling the tank. In these cases, the bund is intended to capture and contain any leaks.

Most local Councils in New Zealand do not require secondary containment, or bunds - to contain any leaking fuel. However it is good practice to use a bund.



Stability, support and seismic restraint

Support & Restraint –

The area of any footings that rest on earth, e.g. soil, clay, sand, or the like, shall not be less than 2cm² for each litre of tank capacity.

We recommend installing a concrete pad of 100mm thickness for masonry dynabolts or anchor fixing of the tank feet.

Where the height of the centre of gravity of a tank above the foundations is more than twice the least width of the footings, the tank shall be provided with not less than two braces to a wall or similar structure.

The tank should be bolted into place with a minimum of four M10 masonry anchors.

Location and separation distances

Proximity to walls and boundaries –

Distance (A) must be 20mm or more from masonry or concrete walls.

Distance (A) must be 100mm or more from timber or other material walls.

Tank may intrude into required minimum boundary setback distances by no more than 620mm. Or adjacent to a 90mm thick masonry or concrete boundary wall with a clear passageway of 500mm provided.

Distance (E) must be 350mm or more for a 90mm masonry or concrete wall.

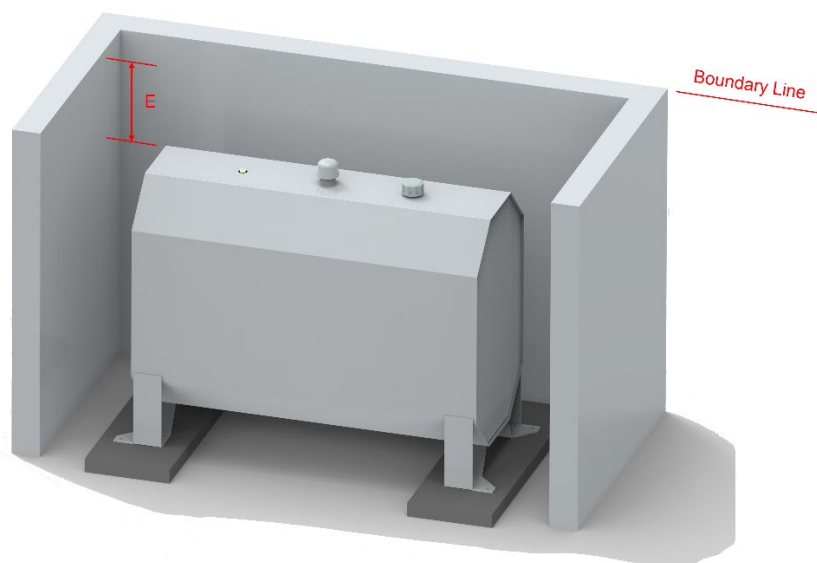

Proximity to building openings –

Distance **(B)** to tank vents to be 1.0m or more from openings or windows.

Tank must be more than 2.5m from any window of adjoining properties.

Proximity to building services –

Distance **(C)** must be 1.8m or more from flue or chimney.

Distance **(D)** must be 3.0m or more from fixed LPG storage tank or 1.0m from exchange cylinders.

Fill point access –

Distance from the parking position of a filling vehicle to the filler must be 45m or less (along an acceptable route for the filler hose must take).

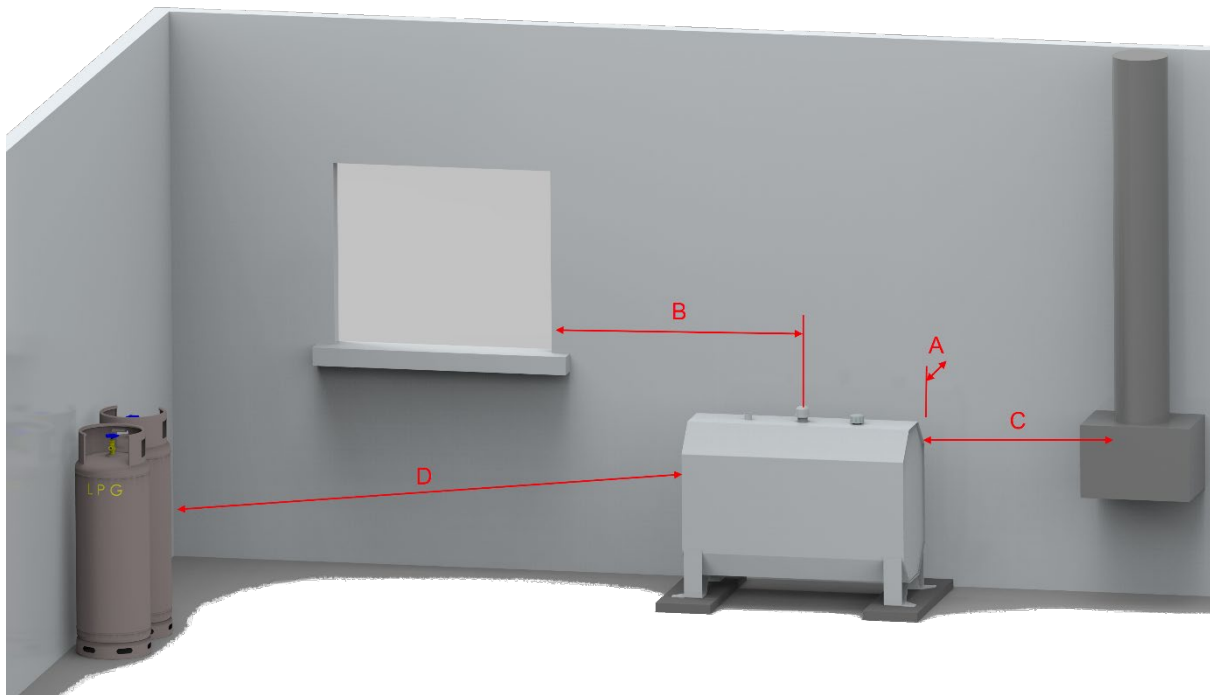

Approvals

Requirements can vary from one public authority or agency to the next. Although this advice has been put together in adherence with current standards and codes of practice, these may not meet all of the requirements for your installation.

Ensuring that local authority requirements are met is the responsibility of the installer – so check with your local council.

Accessories

Hazard Decals are useful in the event of an emergency, so that firefighters or police have the information on the chemicals they are dealing with. Some authorities may require this.



Dipstick for checking / measuring fuel levels. This quick and easy option for assessing how full your tank is, comes marked for dipping through the tank filler port and viewing the amount of it covered by diesel.

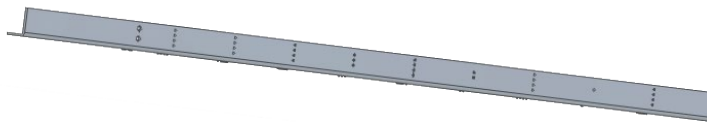

Lockable Filler Cap is a good choice for installations that can be accessed by the public, to secure the fuel. A separate padlock is required to lock the cap for controlled access to the filler port.



Extension Legs are available in various lengths if the tank must be raised above the footings so that adequate gravity feed can be achieved for your heating unit.

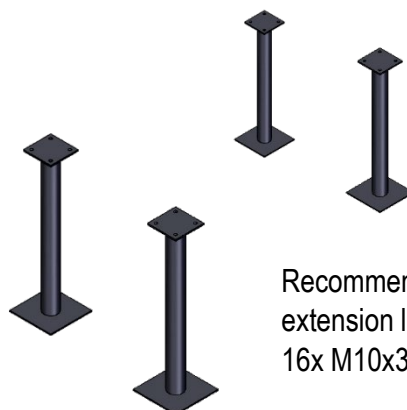

Recommended fastenings for extension legs are:
16x M10x30 galv bolt & nyloc nut.