

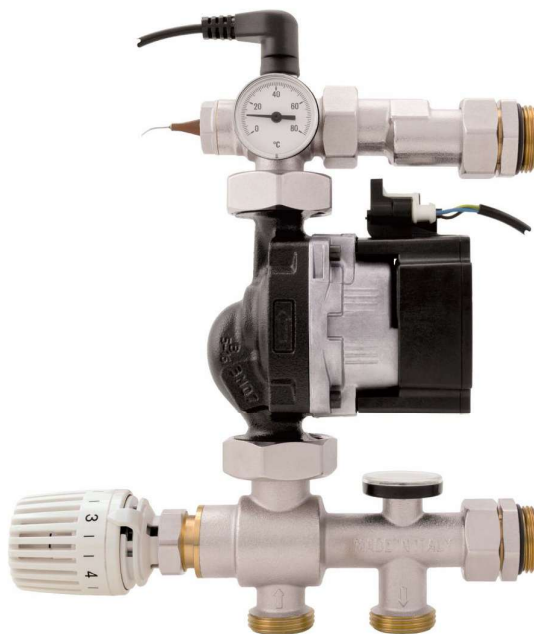

TECHNICAL CATALOGUE

# SET POINT REGULATING UNIT



## > THE COMPANY

ITAP SpA, founded in Lumezzane (Brescia) in 1972, is currently one of the leading production companies in Italy of **valves, fittings and distribution manifolds** for plumbing and heating systems.

Thanks to a fully automated production process, with 85 transfer machines and 55 assembly lines, it is capable of producing 400,000 pieces per day.

Our innate pursuit for innovation and observance of technical regulations is supported by the company certification ISO 9001. The company has always considered its focus on quality as the main tool to obtain significant business results: today ITAP SpA is proud to offer products bearing the approval of numerous international certifying bodies.

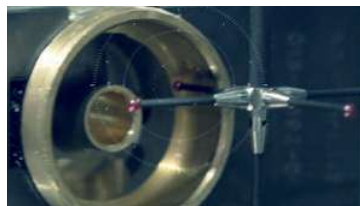
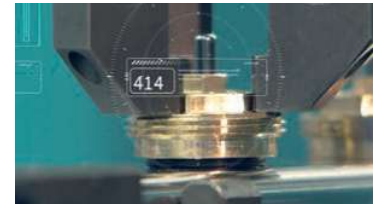

> ITAP products have obtained approvals by more than 30 certification bodies from all over the world.

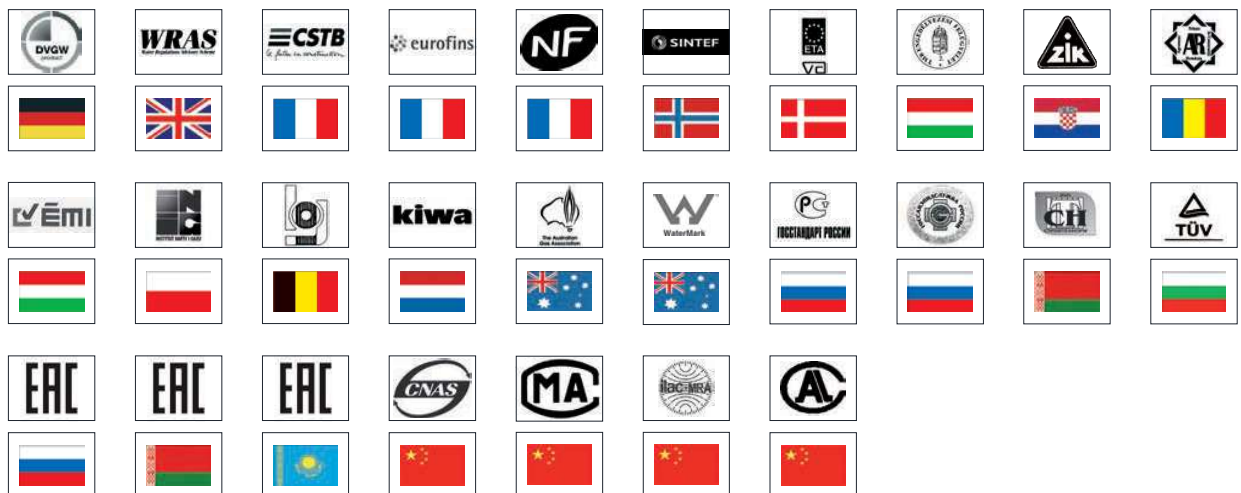



# SET POINT REGULATING UNIT

## 949 Set point regulating unit

The set point regulating unit is used for underfloor heating systems and installed directly on the manifold in the box, thanks to its small overall dimensions.

The minimum depth of the metal box required for the installation of the regulation unit is 90 mm.

The regulation consists of lowering and keeping constant the temperature of the medium fluid using a 3-way mixing valve equipped with an adjustable thermostatic head with a built-in sensor.

A circulation pump (available on request) allows fluid to circulate in the pipes, while a safety thermostat limits the maximum temperature.

### SET POINT REGULATING UNIT



#### 949CPF

With low energy consumption pump.

MEASURE	PRESSURE	CODE	PACKING
1"	6bar/87psi	9490100200CPF	1/2

#### 949SPF

Without low energy consumption pump.

MEASURE	PRESSURE	CODE	PACKING
1"	6bar/87psi	9490100200SPF	1/4

### CERTIFICATIONS



### TECHNICAL SPECIFICATIONS

Consisting of:

- 3-way mixing valve
- Thermostatic head with built-in sensor
- Safety cutoff (factory set at 55°C)
- Thermometer (scale 0°-80°C) fitted to the flow and return pipes
- Low energy consumption pump (on demand)

Technical specifications:

- Medium fluid: water, glycolate solutions max. 30%
- Temperature setting: 20°C – 55°C
- Maximum working pressure: 6 bar
- Body and fittings: nickel-plated brass
- Available size: 1"
- ISO 228 threads (equivalent to DIN EN ISO 228 and BS EN ISO 228)

For a right installation of the set point regulating unit we suggest to use one of the following mounting brackets:

- Art. 498STK with centres distance mm 200 and offset mm 12.
- Art. 949ST.



# SET POINT REGULATING UNIT

## OVERALL DIMENSIONS

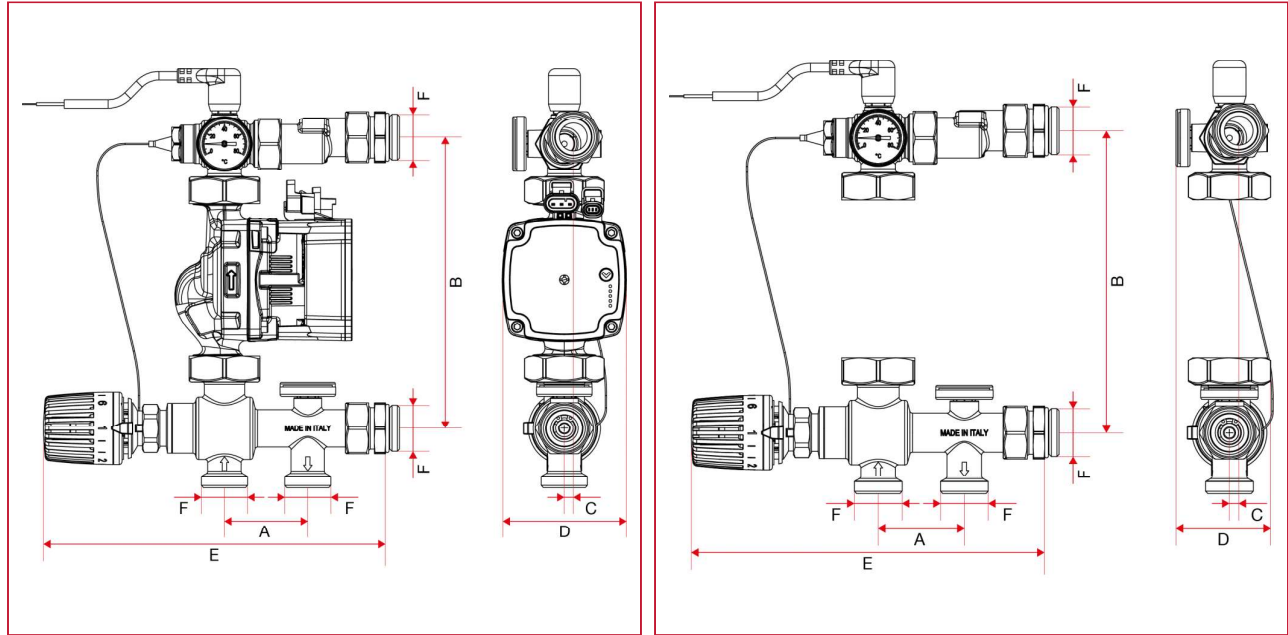

### 949CPF

	1"
A	60
B	200 - 210
C	6,5
D	90
E	250
F	1" M ISO228
Kg/cm2 bar	6
LBS - psi	87

### 949SPF

	1"
A	60
B	200-210
C	6,5
D	66
E	250
F	1" M ISO228
Kg/cm2 bar	6
LBS - psi	87



# SET POINT REGULATING UNIT

## MATERIALS

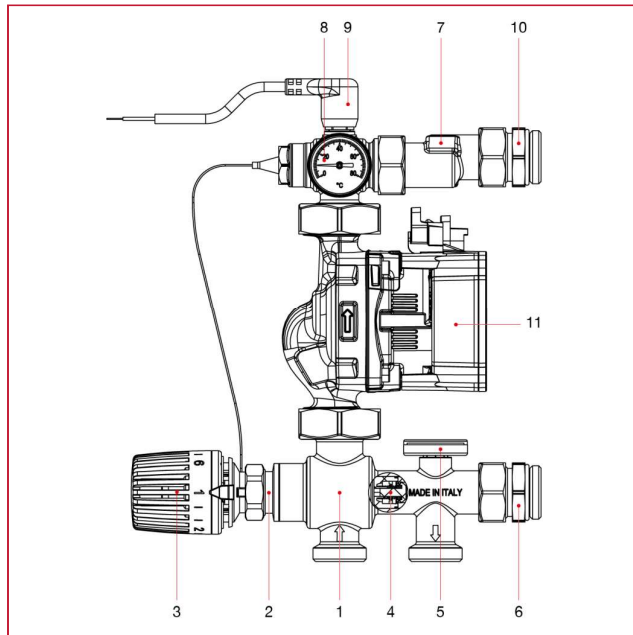

POS.	DESCRIPTION	N.	MATERIAL
1	Mixing valve	1	Nickel-plated brass
2	Bonnet M30 x 1,5	1	Brass
3	Thermostatic control	1	ABS
4	Check Valve	1	POM
5	Return circuit temperature gauge	1	ABS
6	Return circuit connection	1	Brass
7	Offset supply manifold	1	Nickel-plated brass
8	Supply circuit temperature gauge	1	ABS
9	Safety thermostat	1	Aluminium
10	Supply circuit connection	1	Brass
11	High efficiency circulator	1	Cast iron



# SET POINT REGULATING UNIT

## INSTRUCTIONS



### WARNINGS

The following instructions must be read and understood before installation, commissioning and maintenance of the manifold.



### CAUTION

Failure to follow these instructions may result in a safety hazard.

### FUNCTION

The regulation unit functions to lower and maintain the temperature of the heat transfer fluid through a 3-way mixing valve. The reduced footprint of only 90 mm in depth allows it to accommodate directly on board the manifold, in low-thickness walls.

### INSTALLATION

The regulation unit must be installed by a qualified installer in accordance with national regulations and/or local requirements. If the control units are not installed, put into service, and maintained properly according to the instructions in this manual, they may not work properly and may put the user at risk.

Make sure that all connection fittings are hydraulically sealed. When making hydraulic connections, be careful not to over-raise the threads mechanically. Over time, breaks may occur with hydraulic leaks to damage to things and/or people.

Water temperatures above 50 ° C can cause severe burns. During installation, commissioning and maintenance of the control units, take the necessary steps to ensure that such temperatures do not endanger people.

### COMPONENTS:

1. Mixing valve
2. Bonnet M30 x 1,5
3. Thermostatic control
4. Check valve
5. Return circuit temperature gauge
6. Return circuit connection
7. Offset supply manifold
8. Supply circuit temperature gauge
9. Safety thermostat
10. Supply circuit connection
11. High efficiency circulator



# SET POINT REGULATING UNIT

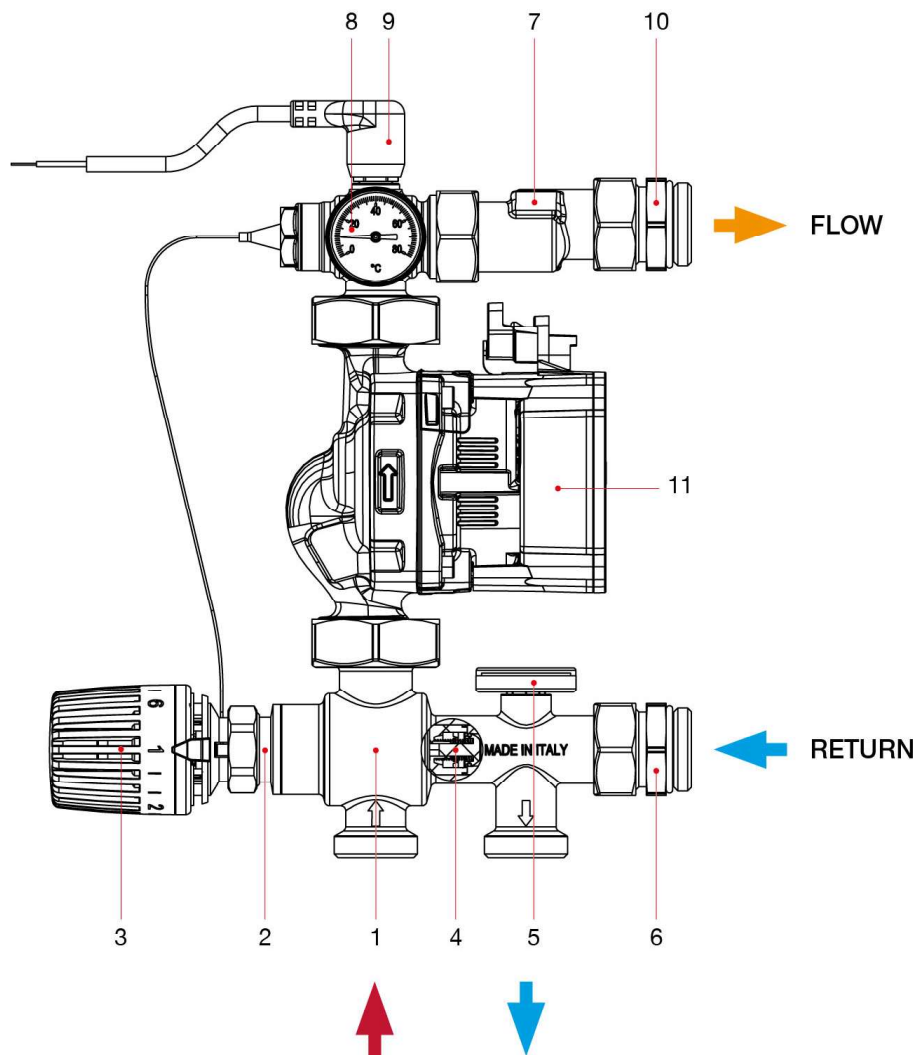

Regulation of the flow temperature:

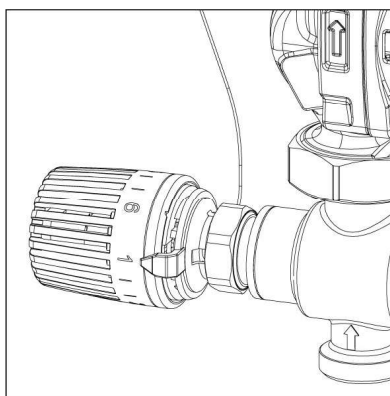

1	2	3	4	5	6
20°C	30°C	40°C	50°C	60°C	70°C



## SET POINT REGULATING UNIT

The thermostatic head adjusts the flow water temperature in the low temperature circuit. To set the temperature, simply rotate the head to the desired value, matching the adjustment scale with the thermostatic head indicator.

Once the temperature has been set, check with the thermometer on the supply circuit that the temperature corresponds to the desired value.

Important: The safety thermostat is factory-set at 55 °C in normally closed condition.

Circulator characteristics:

The circulator can be set to operate in proportional pressure (PP), constant pressure (CP) or constant curve (CC) mode. For underfloor heating circuits, the recommended mode is constant pressure (CP), so that the available head is kept constant regardless of the heat demand of the system. For each mode, 3 different speed levels are available: lower (1), intermediate (2) and higher (3). Using the AUTOADAPT (AA) function, the circulator adapts its performance automatically based on the size of the system and the varying conditions over time.

To set up the product, use the button on the control panel. Each time the button is pressed, the pump setting changes. The LEDs will indicate the selected control mode, according to the following diagram:

Mode	LED 1	LED 2	LED 3	LED 4	LED 5
PP AA	●				
CP AA		●			
PP 1	●		●		
PP 2	●		●	●	
PP 3	●		●	●	●
CP 1		●	●		
CP 2		●	●	●	
CP 3		●	●	●	●
CC 1			●		
CC 2			●	●	
CC 3			●	●	●

Circulator control logic:

The circulator logic allows you to control the switching on and off of the circulator installed on the regulation unit and the closing and opening of a clean contact for starting the boiler, by means of two analogue inputs: TERM AMB (ambient thermostat) and TERM SIC (safety thermostat).

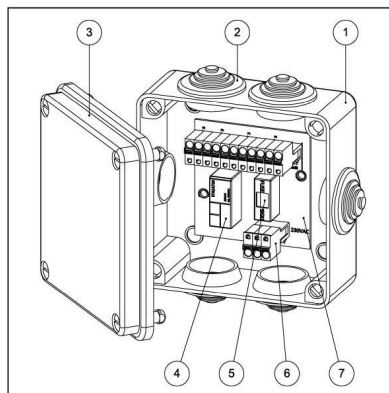

1. Plastic box
2. Rubber clamp
3. Cover
4. Relay
5. Fuse
6. Quick fit connector
7. PCB



# SET POINT REGULATING UNIT

If necessary, the fuse can be replaced with one of the same characteristics (2 A, 250 V, Ø5 x 20 mm).

The circulator logic is built according to the rule of art and in compliance with the directives and laws of the member states of the European Community.

- Electromagnetic Compatibility Standard 89/336/EEC.
- Product electrical safety regulation 2006/95/EEC.

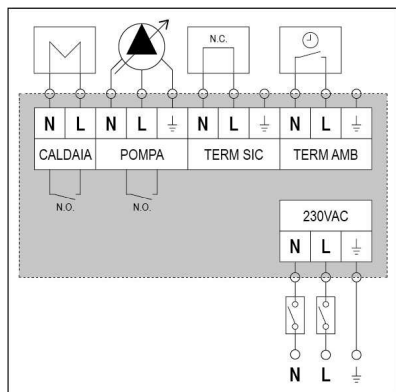

Operating logic (0 = contact open, 1 = contact closed):

TERM AMB	TERM SIC	PUMP	BOILER
0	0	OFF	OFF
0	1	OFF	OFF
1	0	OFF	OFF
1	1	ON	ON

<b>230VAC</b>	Input	230 V AC power supply
<b>TERM AMB</b>	Input	Clean contact for consent from room thermostat or from auxiliary contacts of the electrothermal actuators.
<b>TERM SIC</b>	Input	Clean contact for consent from safety thermostat
<b>POMPA</b>	Output	Circulator power supply
<b>CALDAIA</b>	Output	Normally open clean contact for boiler consent

CIRCULATOR GRAPH



# SET POINT REGULATING UNIT

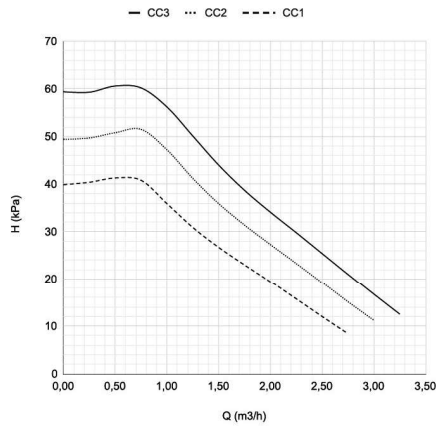

CC (constant speed): the circulator runs on a constant speed curve, which means that it runs at a constant speed or power. The working point of the circulator moves up or down the selected constant curve, according to the heat demand in the system.

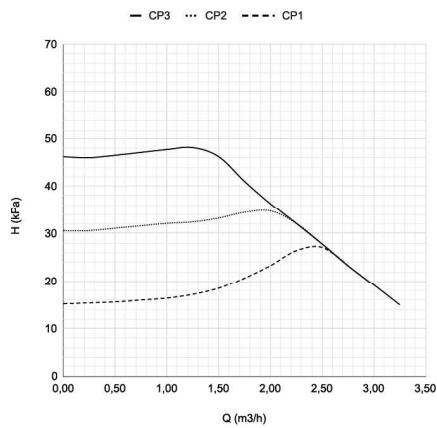

CP (constant pressure): the head (pressure) is kept constant, regardless of the heat demand. The duty point of the circulator will move towards the outside or inside of the selected constant pressure curve, according to the heat demand in the system.

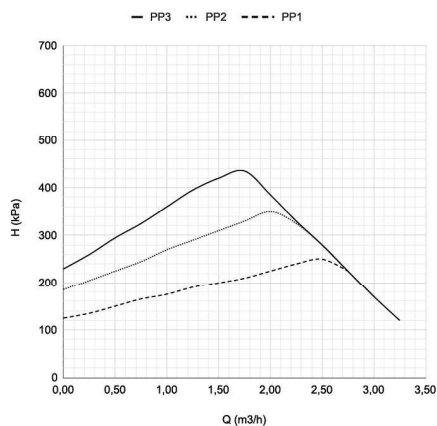

PP (proportional pressure): the head (pressure) decreases as the heat demand decreases and increases as the heat demand increases. The working point of the circulator will move up or down by the selected proportional pressure curve, according to the heat request in the system.

REGULATING UNIT PRESSURE DROP



# SET POINT REGULATING UNIT

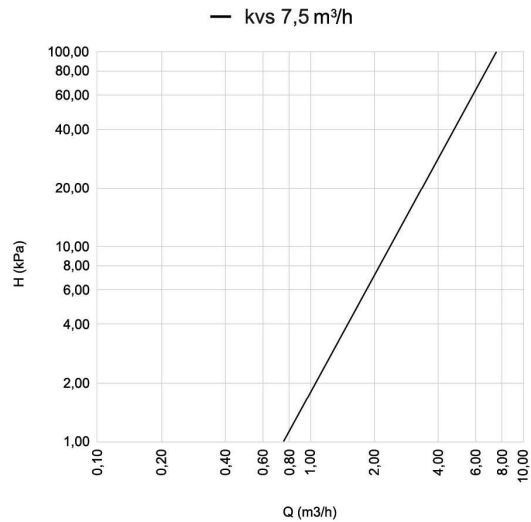

## POSITIONING THE REGULATING UNIT INTO THE METAL BOX

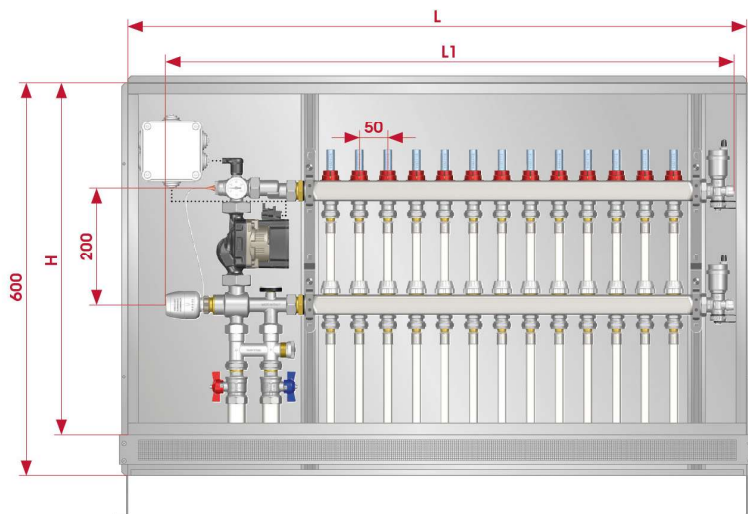

CODE	498.600.500	498.700.500	498.800.500	498.900.500	498.1000.500	498.1100.500
LxH (mm)	600x500	700x500	800x500	900x500	1000x500	1100x500
N. ways	2-3	4-5	6-7	8-9	10-11	12-13
MANIFOLD	1"					
L1	495	595	695	795	895	995

## CONSTRUCTION

The regulating unit is housed in a galvanised steel box (depth 90 mm), which makes it ideal for installation in thin walls. To protect the contents of the enclosure and facilitate the necessary masonry work, it is fitted with a galvanised steel cover, which mounts to the front of the enclosure with four screws. The cover has a 1 cm rim, which acts as a plastering guide. Both the front and back of the enclosure are fitted with mesh to prevent the plaster retracting and cracking. Once the enclosure has been installed and plastered over, remove the cover and fit the door. These are made of galvanised steel with a white (RAL9010) coating and protective film which is removed at the end of the installation process. The base of the enclosure is adjustable vertically by 100 mm, while its door can be adjusted inwards or outwards by 50 mm. The roof of the enclosure has holes for routing the electrical cables.



## SET POINT REGULATING UNIT

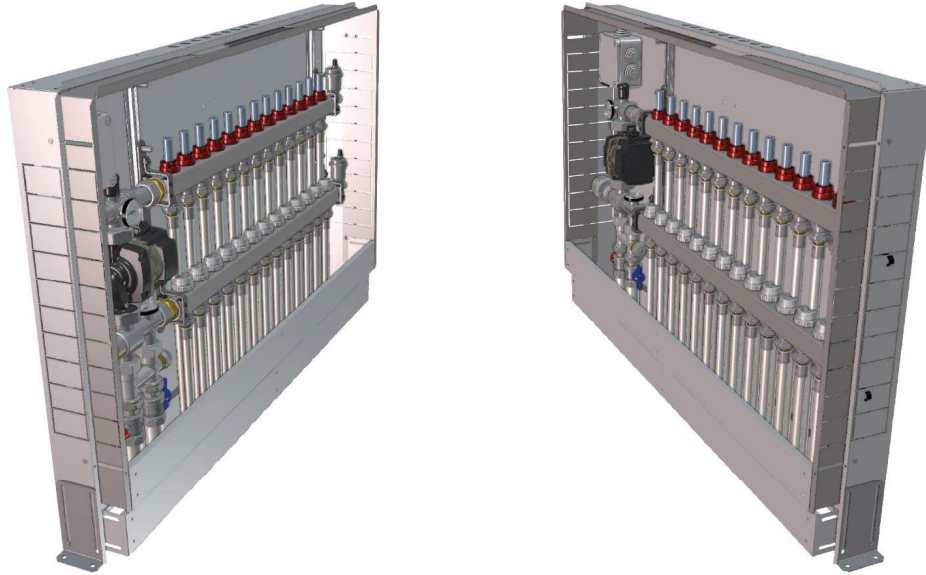

The 3-way mixing valve has 20 mm inside diameter. This large diameter means that the medium can be heated up to the desired temperature quicker than with units with smaller diameter ports. The result is that the circulator pump runs for less time throughout the day, which considerably reduces its power consumption. An additional saving is represented by the use of variable speed circulator pumps compliant with Directive ErP 2015 (starting from January 1st 2013), which considerably reduces power consumption and promote the new concept of eco-design.

### INSTALLATION OF REGULATING UNIT

1. The control unit is supplied with the connection of the main pipes down, with the outlet on the left and the return on the right.
2. Using the swivel fittings, connect the unit to the secondary pipes or distributor manifolds, paying attention to connecting the supply circuit to the outlet at the top and the return circuit on the bottom one.
3. Connect the primary circuit bypass (optional) and the ball valves (optional), paying attention to connecting the supply circuit to the left and the return circuit to the right.
4. Connect the main pipes.

### PRIMARY CIRCUIT BY-PASS

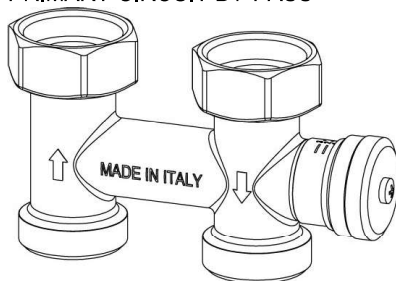

The by-pass for the primary circuit (optional) allows the hydraulic separation between the primary and secondary circuit. This hydraulic separation optimizes the operation of the secondary circuit and prevents changes in the flow rate of the primary from affecting the secondary circuit. The flow rate that passes through the respective circuits depends exclusively on the flow rate characteristics of the pumps, avoiding the mutual influence due to their coupling in series.

An adjustable differential valve is placed on the by-pass, whose intervention value can be changed using the appropriate knob. If the secondary circuit is closed, the differential valve opens to allow the water to return to the boiler.



# SET POINT REGULATING UNIT

Setting	Opening pressure
3	30 kPa
2	20 kPa
1	10 kPa
Completely open	5 kPa

## GENERAL INFORMATION

This appliance may be used only for its intended application. Any other use is improper and dangerous. This appliance is designed for heating water to a temperature below boiling point at atmospheric pressure.

The appliance is designed only for installation indoors, in the room or suitably equipped rooms. It may not be installed or operated outdoors. Installing the unit outdoors may cause malfunction and hazards. For outdoors installations, we recommend the use of equipment designed specifically for such applications.

Before wiring the unit, have all circuit pipes flushed by a professionally qualified technician to remove any residue or impurities capable of compromising the operation of the boiler.

The appliance must be installed in conformity with the instructions given in this manual. The installation must be done by a professional technician, liable for the observance of all applicable local and national legislation published in the official gazette, as well as applicable technical regulations.

Install the appliance only to a closed wall made of non-flammable material, which is flat and vertical and provides the minimum clearances necessary for installation and maintenance.

The installation must be done in compliance with the standards, regulations and instructions given in this manual, which constitute a non-exhaustive list of applicable regulations which are subject to change with developments in good practice. The installation technician is responsible for ensuring compliance with applicable regulations.

The installation must be done in compliance with the standards, regulations and instructions given in this manual, which constitute a non-exhaustive list of applicable regulations which are subject to change with developments in good practice. The installation technician is responsible for ensuring compliance with applicable regulations.

Do not leave the packaging materials within the reach of children as they are potentially hazardous. The manufacturer is not liable for any damage or injury to property, persons or animals resulting from failure to comply with the above instructions.

This manual is an integral and essential part of the product and is supplied with every regulation unit sold. Keep it for reference.

Please read the information in this manual carefully; it provides important information for the use and maintenance of the product. Before cleaning or servicing the product, disconnect it from its power supply with the system's master power switch or circuit breakers. If the unit fails or malfunctions, switch it off immediately; do not attempt to repair it or work on it in any way. It may only be repaired by a legally authorised technician.



## CAUTION

Leave this manual for use and service of the user.

The installation and wiring must be done by a qualified technician.

We reserve the right to make improvements and changes to the products described herein and to the relative technical data, at any time and without forewarning.