

INSTALLATION-OPERATING-SERVICE MANUAL



Air/water chillers and heat pumps with axial-flow fans and pump assembly.

**r HFC
R-410A**

MICS FF

MICS-N FF

0072÷0182

U	I	A	General warnings	2	I	A	Operating limits	16	
U	I	A	Fundamental safety rules	2	I	A	Hydraulic data	17	
U	I	A	Identification	3	A		Checking and starting up the unit	18	
	I	A	Receiving and handling the product	3	U	I	A	Activating and deactivating the unit	20
	I	A	Description of standard unit	4	A		Setting service parameters	20	
	I		Dimensioned drawings	5	I	A	Displaying alarms	21	
	I		Installation	6	I	A	Operating characteristics	22	
	I	A	Hydraulic connections	6	A		Shutting down for long periods	23	
	I	A	Electrical connections	8	A		Routine maintenance	23	
	I	A	General technical data	12	A		Extraordinary maintenance	23	
	A		Cooling performance MICS	13	I	A	Troubleshooting	24	
	A		Cooling performance MICS-N	14	U	I	A	Useful information	26
	A		Heating performance MICS-N	15					

The following symbols are used in this publication and inside the unit:



User



Important



Danger moving blades



Install



Prohibition



Danger high temperatures



Assistance



Danger voltage



Eurovent certification program.

The manufacturer reserves the right to modify the data in this manual without warning.

ENVIRONMENTAL INFORMATION: This equipment contains fluorinated greenhouse gases covered by the Kyoto Protocol. It should only be serviced or dismantled by professional trained personnel. R410A GWP=1975

 **These units have been designed** to chill and/or heat water and must be used in applications compatible with their performance characteristics.

Incorrect installation, regulation and maintenance or improper use absolve the **manufacturer** from all liability, whether contractual or otherwise, for damage to people, animals or things. Only those applications specifically indicated in this list are permitted.

Read this manual carefully. All work must be carried out by qualified personnel in conformity with legislation in force in the country concerned.

The guarantee is invalidated if the above instructions are not respected and if the unit is started up for the first time without the presence of personnel authorised by the Company (where specified in the supply contract) who should draw up a “start-up” report.

The documentation supplied with the unit must be consigned to the owner who should keep it carefully for future consultation in the event of

maintenance or service.

When the items are consigned by the carrier, check that the packaging and the unit are undamaged. If damage or missing components are noted, indicate this on the delivery note. A formal complaint should be sent via fax or registered post to the After Sales Department within eight days from the date of receipt of the items.

FUNDAMENTAL SAFETY RULES

When operating equipment involving the use of electricity and water, a number of fundamental safety rules must be observed, namely:

 **The unit must not be used** by children or by unfit persons without suitable supervision.

Do not touch the unit with bare feet or with wet or damp parts of the body.

Do not carry out cleaning operations without first disconnecting the system from the electricity supply by placing the mains switch in the “off” position.

Do not modify safety or regulation devices without authorisation and instructions from the manufacturer.

Do not pull, detach or twist the electrical cables coming from the unit, even when disconnected from the mains electricity supply.

Do not open doors or panels providing access to the internal parts of the unit without first ensuring that the mains switch is in the off position.

Do not introduce pointed objects through the air intake and outlet grills.

Do not dispose of, abandon or leave within reach of children packaging materials (cardboard, staples, plastic bags, etc.) as they may represent a hazard.

 **Respect safety distances between** the unit and other equipment or structures. Guarantee adequate space for access to the unit for maintenance and/or service operations;

Power supply: the cross section of the electrical cables must be adequate for the power of the unit and the power supply voltage must correspond with the value indicated on the respective units. All units must be earthed in conformity with legislation in force in the country concerned.

Hydraulic connections should be carried out as indicated in the instructions to guarantee correct operation of the unit. Empty the water circuit or add glycol if the unit is not used during the winter.

Handle the unit with the utmost care (see weight distribution table) to avoid damage.

The air-cooled chillers with axial-flow fans operate with refrigerant R410A and are suitable for installation outdoors. The units satisfy the essential requirements of directives 98/37/EC, 73/23/EEC, 89/326/EEC, 97/23/EEC and subsequent amendments.

They are factory tested and on site installation is limited to water and electrical connections.

STRUCTURE

Panels and base are made from galvanised steel plate painted with epoxy powder to ensure total resistance to atmospheric agents.

COMPRESSORS

Hermetic rotary scroll compressor with thermal cut-out.

CONDENSING COILS

Made from copper tubes and aluminium fins with a large exchange surface.

EVAPORATOR

AISI 316 stainless steel plate type evaporator complete with **differential pressure switch**. Casing lined with anti-condensate closed cell neoprene cladding.

PUMPS

Multistage centrifugal pump with stainless steel hydraulic assembly and corrosion prevention device to prolong the working life of the pump. Over-sized watertight bearings with gasket ring resistant to thermal expansion eliminate the problem of seizure.

PUMP ASSEMBLY

Pump assembly with expansion tank, safety valve, manual filling assembly, pressure gauge and pump.

FANS

External impeller axial-flow fans. Six-pole electric motor with built-in thermal cut-out. Housed in aerodynamic tubes with accident prevention grill. **Device for operation with low outside air temperatures:** continuous fan rotation speed control via **pressure transducer**.

REFRIGERANT CIRCUIT

Refrigerant circuit featuring the following components: filter, liquid flow indicator, thermostatic expansion valve with external equaliser. Pressure switches for controlling suction and discharge pressure. Unit supplied complete with non-freezing oil and R410A refrigerant charge, **factory tested**.

POWER AND CONTROL ELECTRICAL PANEL

Power and control electrical panel constructed in accordance with IEC 204-1/EN60204-1, complete with compressor contactor and **thermal solenoid switch and door lock safety device**. Control via "HSW8" control panel.

OPTIONAL ACCESSORIES

- Removable metal mesh filter for water circuit
- Rubber vibration dampers.
- Remote keyboard kit.
- Coil protection grill kit.

The above accessories are optional. Consult the relative documentation for assembly instructions and technical data.

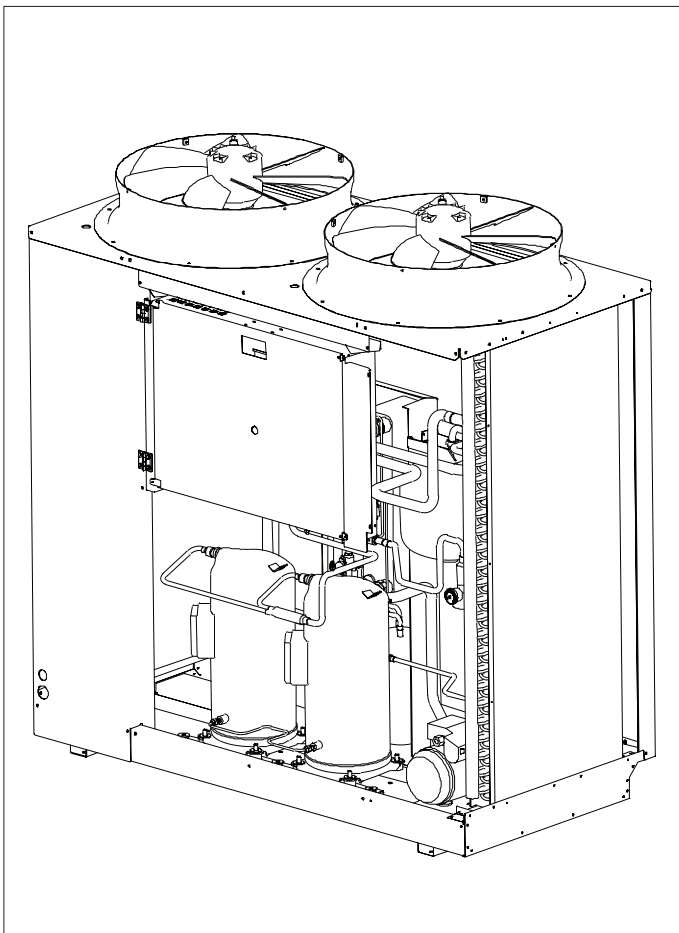

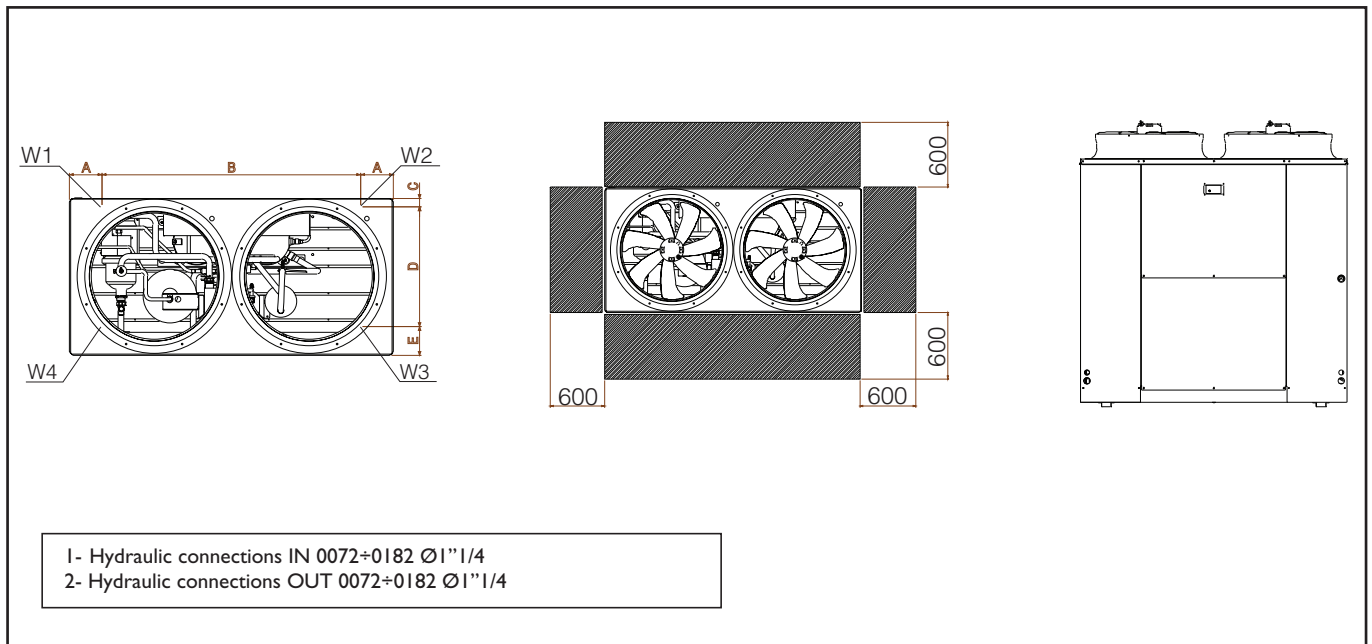

Dimension	0072	0092	0122	0152	0182
A	120	120	165	165	165
B	800	800	1300	1300	1300
C	44	44	44	44	44
D	602	602	602	602	602
E	144	144	144	144	144

Weight distribution in operation MICS	0072	0092	0122	0152	0182
W1	97	103	128	141	151
W2	89	95	118	129	137
W3	58	62	77	85	90
W4	66	70	87	95	102
Tot	310	330	410	450	480

Weight distribution in operation MICS-N	0072	0092	0122	0152	0182
W1	103	109	138	151	160
W2	95	101	126	137	146
W3	62	66	83	90	96
W4	70	74	93	102	108
Tot	330	350	440	480	510

CHOICE OF INSTALLATION SITE

Before installing the unit, agree with the customer the site where it will be installed, taking the following points into consideration:

- check that the fixing points are adequate to support the weight of the unit;
- pay scrupulous respect to safety distances between the unit and other equipment or structures to ensure that air entering the unit and discharged by the fans is free to circulate.
- The unit must be installed in a space designed to house technical installations dimensioned according to legislation in force in the country concerned and large enough to allow access for maintenance.

POSITIONING

Before handling the unit, check the capacity of the lifting equipment used, respecting the instructions on the packaging.

To move the unit in the horizontal, make appropriate use of a

lift truck or similar, bearing in mind the weight distribution of the unit. To lift the unit, insert tubes long enough to allow positioning of the lifting slings and safety pins in the special holes in the base of the unit.

To avoid the slings damaging the unit, place protection between the slings and the unit. Position the unit in the site indicated by the customer. Place either a layer of rubber (min. thickness 10 mm) or vibration damper feet (optional) between the base and support surface. Fix the unit, making sure it is level and that there is easy access to hydraulic and electrical components. If the site is exposed to strong winds, fix the unit adequately to the support surface using tie rods if necessary.

HYDRAULIC CONNECTIONS

The choice and installation of components is the responsibility of the installer who should follow good working practice and current legislation. Before connecting the pipes, make sure they do not contain stones, sand, rust, dross or other foreign bodies which might damage the unit. Construction of a bypass is recommended to enable the pipes to be washed through without having to disconnect the unit (see drain valves). The connection piping should be supported in such a way as to avoid it weighing on the unit. It is recommended that the following devices are installed in the water circuit of the evaporator:

1. Two pressure gauges with a suitable scale (inlet and outlet).
2. Two vibration damper joints (inlet and outlet).
3. Two gate valves (normal in inlet and calibrating in outlet).

4. A flow switch (inlet).
5. Two thermometers (inlet and outlet).
6. An inlet filter as close as possible to the evaporator and positioned to allow easy access for routine maintenance.

The flow of water to the refrigerating assembly must conform to the values given on page 12. The flow of water must be maintained constant during operation. The water content of the unit must be such as to avoid disturbing operation of the refrigerant circuits. See the values given on page 17.

HYDRAULIC CIRCUIT

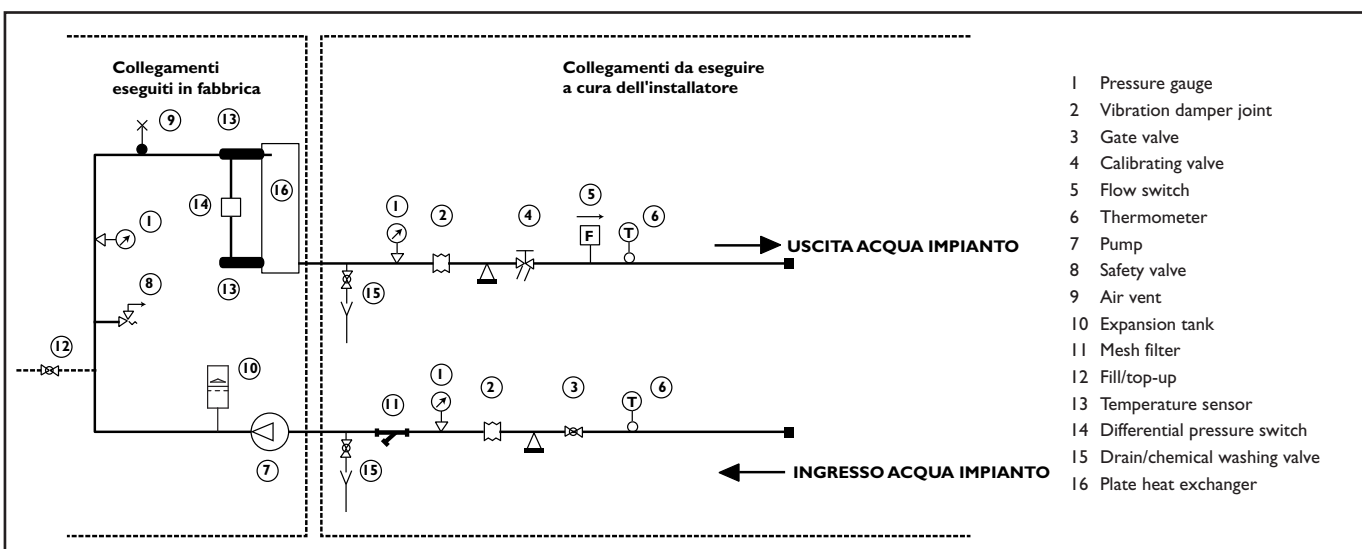

⚠ Installations containing antifreeze or covered by specific legislation must be fitted with hydraulic disconnectors.

The manufacturer is not liable for obstruction, breakage or noise resulting from the failure to install filters or vibration dampers.

⚠ Particular types of water used for filling or topping up must be treated with appropriate treatment systems. For reference values, see the table.

SIZE AND POSITION OF CONNECTIONS

Dimensione	0072	0092	0122	0152	0182
A (mm)	100	100	260	260	260
B (mm)	226,5	226,5	363	363	363
C (mm)	63	63	63	63	63
Hydraulic connections (Ø)	G1-1/4	G1-1/4	G1-1/4	G1-1/4	G1-1/4

PH	6-8
Electrical conductivity	less than 200 mV/cm (25°C)
Chlorine ions	less than 50 ppm
Sulphuric acid ions	less than 50 ppm
Total iron	less than 0,3 ppm
Alkalinity M	less than 50 ppm
Total hardness	less than 50 ppm
Sulphur ions	none
Ammonia ions	none
Silicon ions	less than 30 ppm

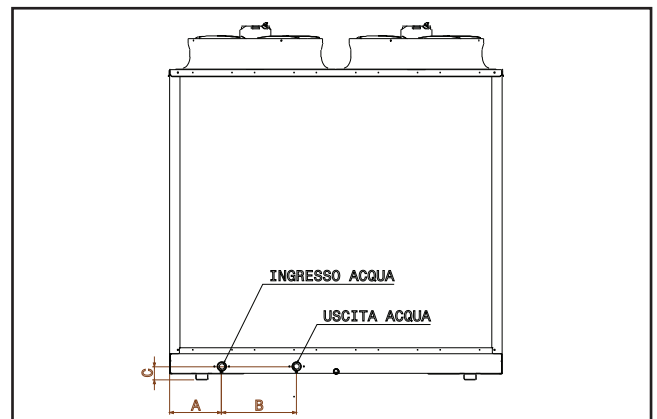

FILLING THE INSTALLATION

- Remove the inspection panel.
- Before filling, check that the installation drain valve is closed.
- Open all installation, appliance and terminal air vents.
- Open the gate valves.
- Begin filling, slowly opening the water filling cock inside the unit.
- When water begins to leak out of the terminal air vent valves, close them and continue filling until the pressure gauge indicates a pressure of 1.5 bar.
- Replace the inspection panel

⚠ The installation must be filled to a pressure of between 1 and 2 bar.

It is recommended that this operation be repeated after the unit has been operating for a number of hours. The pressure of the installation should be checked regularly and if it drops below 1 bar, the water content should be topped-up.

Check the hydraulic tightness of joints.

EMPTYING THE INSTALLATION

- Remove the inspection panel.
- Before emptying, place the mains switch in the "off" position.
- Make sure the installation fill/top-up water cock is closed.
- Open all the installation air vent valves, the drain cock and the terminals.
- Replace the inspection panel

⚠ If the fluid in the circuit contains antifreeze, it should not be allowed to drain freely as it is pollutant. It should be collected for possible reuse. When draining after heat pump operation, take care as the water may be hot (up to 50°).

The **MICS / MICS-N** chillers leave the factory already wired, and ready for connection to the mains electricity supply and for the flow switch and remote ON/OFF switch to be connected. All the above operations must be carried out by qualified personnel in compliance with the legislation in force. For all electrical work, refer to the electrical wiring diagrams in this manual. You are also recommended to check:

- That the characteristics of the mains electricity supply are adequate for the power input values indicated in the electrical characteristics table below, also bearing in mind the possible use of other equipment at the same time.

⚠ Power to the unit must be turned on only after installation work (mechanical, hydraulic and electrical) has been completed.

All electrical connections must be carried out by qualified personnel in accordance with legislation in force in the country concerned.

Respect instructions for connecting phase, neutral and earth conductors. The power line should be fitted upstream with a suitable device to protect against short-circuits and leakage to earth, isolating the installation from other equipment.

⚠ Voltage must be within a tolerance of $\pm 10\%$ of the rated power supply voltage for the unit (for three phase units, the unbalance between the phases must not exceed 3%). If these parameters are not respected, contact the electricity supply company.

For electrical connections, use double insulation cable in conformity with current legislation in the country concerned. **Install**, if possible near the unit, an appropriate protection device to isolate the unit from the mains supply. This should have a delayed characteristic curve, contacts opening by at least 3 mm and an adequate interruption and residual current protection capacity.

If these devices are not visible from the unit, they should be lockable.

An efficient earth connection is obligatory. Failure to earth the appliance absolves the manufacturer of all liability for damage.

In the case of three phase units, ensure the phases are connected correctly.

⚫ Do not use water pipes to earth the unit.

MICS ELECTRICAL DATA

Model	Electrical elettrica (V-Ph-Hz)	Rated values (1)										Max. values (3)		FUSES Glass 5x20mm 250V			
		Compressor			Fans		Pump		Total			F.L.I. (kW)	F.L.A. (A)	FU1	FU4	FU5	FU6
		F.L.I. (kW)	F.L.A. (A)	L.R.A. (A)	F.L.I. (kW)	F.L.A. (A)	F.L.I. (kW)	F.L.A. (A)	F.L.I. (kW)	F.L.A. (A)	F.L.I. (kW)						
0072	400-3 N ~ 50	5,9	11,2	48	0,6	2,8	0,7	4,8	7,2	18,8	9,9	23,6	1A	1A	0,5A	3,15	
0092	400-3 N ~ 50	8,7	16,3	64	0,6	2,8	0,7	4,8	10,0	23,9	12	27,6	1A	1A	0,5A	3,15	
0122	400-3 N ~ 50	9,5	16,6	74	1,2	5,6	0,7	4,8	11,4	27	19	40,4	1A	1A	0,5A	3,15	
0152	400-3 N ~ 50	12,2	22,6	95	1,2	5,6	1,3	9,0	14,7	37,2	19,8	46,6	1A	1A	0,5A	3,15	
0182	400-3 N ~ 50	14,3	25,9	111	1,2	5,6	0,9	5,4	16,4	36,9	25,1	53,0	1A	1A	0,5A	3,15	

MICS-N ELECTRICAL DATA

Model	Electrical elettrica (V-Ph-Hz)	Rated values (2)										Max. values (3)		FUSES Glass 5x20mm 250V			
		Compressor			Fans		Pump		Total			F.L.I. (kW)	F.L.A. (A)	FU1	FU2	FU3	FU4
		F.L.I. (kW)	F.L.A. (A)	L.R.A. (A)	F.L.I. (kW)	F.L.A. (A)	F.L.I. (kW)	F.L.A. (A)	F.L.I. (kW)	F.L.A. (A)	F.L.I. (kW)						
0072	400-3 N ~ 50	5,9	11,2	48	0,6	2,8	0,7	4,8	7,2	18,8	9,9	23,6	1A	1A	0,5A	3,15	
0092	400-3 N ~ 50	8,0	14,9	64	0,6	2,8	0,7	4,8	9,3	22,5	12	27,6	1A	1A	0,5A	3,15	
0122	400-3 N ~ 50	10,0	17,5	74	1,2	5,6	1,1	7,6	12,3	30,7	19,4	43,2	1A	1A	0,5A	3,15	
0152	400-3 N ~ 50	12,8	23,7	95	1,2	5,6	0,9	5,4	14,9	34,7	19,4	43,0	1A	1A	0,5A	3,15	
0182	400-3 N ~ 50	14,2	25,7	111	1,2	5,6	0,9	5,4	16,3	36,7	25,1	53,0	1A	1A	0,5A	3,15	

F.L.I. power input
F.L.A. current input
L.R.A. compressor start-up current

- (1) Outside air temperature 35°C - Water temperature at evaporator 12/7°C.
- (2) Outside air temperature 7°C - Water temperature at condenser 40/45°C.
- (3) These values should be used to dimension protection switches and power cables.

ACCESSING THE ELECTRICAL PANEL

The electrical panel is located inside the unit at the top of the technical compartment where the various components of the refrigerant circuit are also to be found. To access the electrical panel, remove the front panel of the unit by undoing the metric screws. To access the components in the electrical panel and the terminal boards, undo the screws and remove the part of the panel.

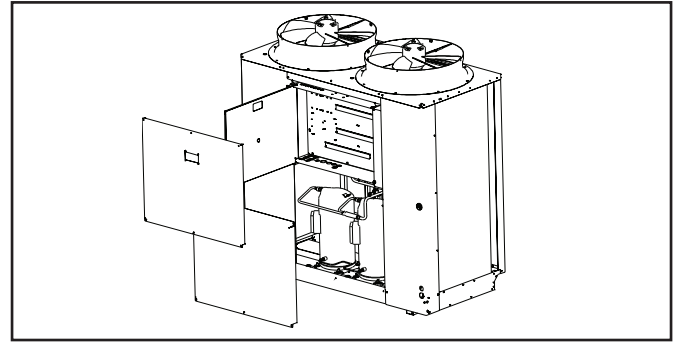

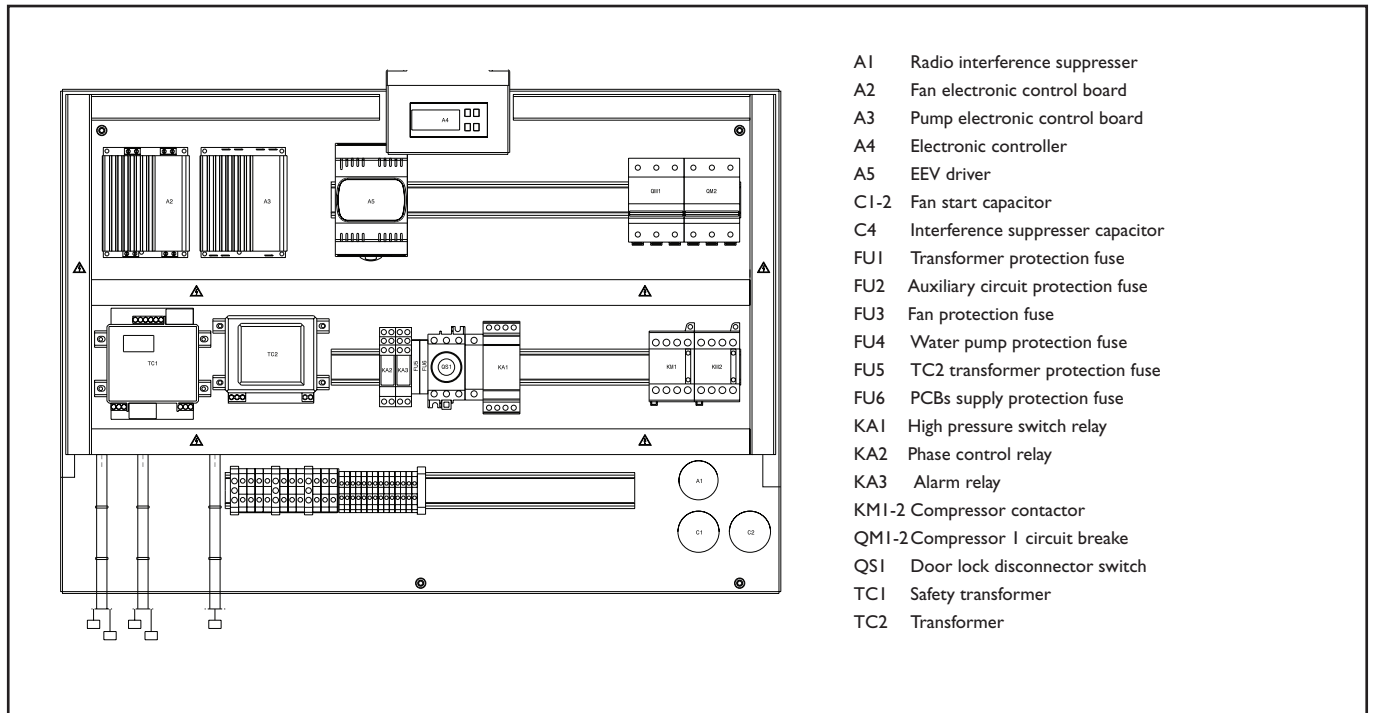

ELECTRICAL PANEL LAYOUT



 **Conduits containing live wires, even when the door lock disconnecting switch is off**

ELECTRICAL POWER CONNECTIONS

For the functional connection of the unit, bring the power supply cable to the electrical panel inside the unit and connect it to terminals U-V-W N and  respecting (U-V-W) phases, (N) neutral and () earth.

AUXILIARY CONNECTIONS

All terminals referred to in the explanations below are to be found on the terminal board inside the electrical panel and described as “installer terminals”.

REMOTE START UP AND SHUT DOWN

To be able to use a remote switching on and off device, a switch must be connected to terminals 13 and 14 of the installer terminal block. For timed operation, connect a daily or weekly timer between terminals 13 and 14 (see wiring diagram). Select the parameter H07 from the control panel HSW8 and put it to the value 1.

REMOTE HEATING/COOLING CONTROL

To fit a remote heating/cooling selector, the jumper must be replaced with a switch connected to terminals 11 and 12 on the installer terminal board. To activate the command, proceed as follows:

- Select the parameter H06 on the HSW8 control panel and set it to 1.

REMOTE ALARM

For remote display of unit shut-down due to malfunction, an audible or visual alarm warning device can be connected between terminals 19 and 20. Connect the phase to terminal 20 and the alarm signal device between terminal 19 and the neutral.

REMOTE KEYBOARD KIT

The remote keyboard kit can be used to display all unit functions and access the parameters of the electronic board from a point located at some distance from the unit itself.

To install the kit, follow the instructions accompanying the kit.



To avoid interference due to magnetic fields, the use of shielded cable is recommended. The cable should not be more than 100m long.

CONNECTING A FLOW SWITCH

If a flow switch is to be used, connect it to terminals 9 and 10 on the installer terminal board, after removing the jumper.

COMPRESSOR ON SIGNAL

If the operation of the compressor needs to be signalled in a remote position, terminals 17 and 18 can be connected to an audible or visual signal device. Connect the phase to terminal 18 and the signal device between terminal 17 and the neutral.

WIRING DIAGRAM

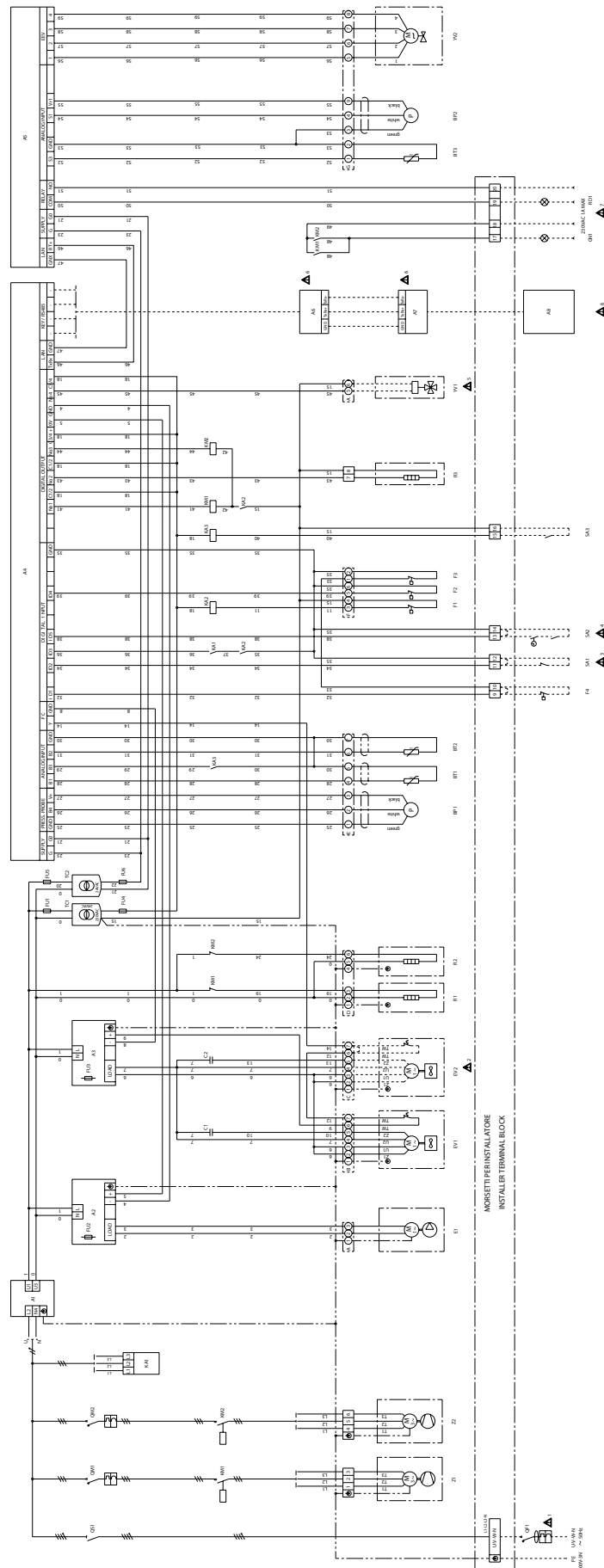

Factory installed components

- A1 Noise suppression filter
- A2 Plant water pump control board
- A3 Condensation fan control board
- A4 Electronic control
- A5 EEV driver
- A6 RS485 serial interface
- A7 Supply module
- A8 Remote terminal
- BPI Radiometric cond./evap. pressure probe.
- BP2 Low pressure side radiometric pressure probe
- BT1 Inlet water plant temperature sensor
- BT2 Outlet water plant temperature sensor
- BT3 Compressor suction temperature sensor
- CI-2 Fan starting capacitor
- E1 Plant water pump

- EVI-2 Condensing air fan
- F1 High pressure switch
- F2 Low pressure switch
- F3 Water differential pressure switch
- F4 Flow switch
- FU1 TCI transformer protection fuse
- FU2 Auxiliary circuit protection fuse
- FU3 Fan protection fuse
- FU4 Plant water pump protection fuse
- FU5 TC2 transformer protection fuse
- FU6 PCBs supply protection fuse
- GNI Green light (compressor ON)
- KA1 Phase sequence control relay
- KA2 High pressure switch relay
- KA3 Load limitation relay

- KM1 Compressor 1 contactor
- KM2 Compressor 2 contactor
- QF1 Refrigerator group circuit breaker
- QM1 Compressor 1 circuit breaker
- QM2 Compressor 2 circuit breaker
- QSI Door locking circuit breaker
- R1 Compressor 1 crankcase heater
- R2 Compressor 2 crankcase heater
- R3 Frost heater
- RD1 Red warning light (shut-off comp. signal)
- SA1 Heating/cooling switch
- SA2 Timer and/or on-off switch
- SA3 Load limitation switch
- TC1 Insulation transformer
- TC2 230/24VAC transformer

- YV1 Cycle reversing valve
 - YV2 Electronic expansion valve
 - Z1 Compressor 1
 - Z2 Compressor 2
- 1 Switch (optional)
 2 0122-0182 models only
 3 Heating-cooling switch (optional), for models only cooling clamps 8-9 closed
 4 Timer and on-off switch (optional)
 5 Heat pump only
 6 Optional
 7 Pilot lamps (optional)

MICS-N		0072	0092	0122	0152	0182
Cooling capacity (1)	kW	17,3	21,8	30,3	37,4	42,5
Compressor power input (1)	kW	5,9	8,7	9,5	12,2	14,8
Potenza termica (2)	kW	20,2	26,1	33,9	42,6	47,9
Compressor power input (2)	kW	5,9	8,0	10,0	12,8	14,2
Compressors	n°	2	2	2	2	2
Rated water flow (1)	m ³ /h	3,0	3,8	5,2	6,4	7,3
Rated water flow (2)	m ³ /h	3,5	4,5	5,9	7,4	8,3
Residual head	kPa	90	100	100	105	90
Maximum allowable pressure PS ^L _H	Mpa	2,80	2,80	2,80	2,80	2,80
		3,93	3,93	3,93	3,93	3,93
Electrical power supply	V/ph/Hz	400-3 N ~ 50				
Total power input (2)	kW	6,5	8,6	11,2	14,0	15,4
Electrical index of protection	IP	X4				
Fans	n°	1	1	2	2	2
Max. air flow	m ³ /s	2,5	2,5	5,0	4,9	4,9
Noise level (3)	dB(A)	68	68	71	71	71
R410A refrigerant charge	kg	6,6	6,9	11,0	13,3	14,5
Copeland 3MAF (32 cSt)	lt	1,3 + 1,3	2,0 + 2,0	2,0 + 2,0	2,5 + 2,5	3,3 + 3,3
Olio Mobil EAL Artic 22 cc						
ICI Emkarate RL 32 CF						
Operating weight	kg	310	330	410	450	480

MICS		0072	0092	0122	0152	0182
Cooling capacity (1)	kW	18,2	23,0	31,9	39,4	44,7
Compressor power input (1)	kW	5,9	8,7	9,5	12,2	14,3
Compressors	n°	2	2	2	2	2
Rated water flow	m ³ /h	3,1	4,0	5,5	6,8	7,7
Residual head (1)	kPa	130	140	105	125	120
Maximum allowable pressure PS ^L _H	Mpa	2,80	2,80	2,80	2,80	2,80
		3,93	3,93	3,93	3,93	3,93
Electrical power supply	V/ph/Hz	400-3 N ~ 50				
Total power input (1)	kW	6,5	9,3	10,7	13,4	15,5
Electrical index of protection	IP	X4				
Fans	n°	1	1	2	2	2
Max. air flow	m ³ /s	2,5	2,5	5,0	4,9	4,9
Noise level (3)	dB(A)	68	68	71	71	71
R410A refrigerant charge	kg	5,35	4,80	7,25	11,10	11,20
Copeland 3MAF (32 cSt)	lt	1,3 + 1,3	2,0 + 2,0	2,0 + 2,0	2,5 + 2,5	3,3 + 3,3
Olio Mobil EAL Artic 22 cc						
ICI Emkarate RL 32 CF						
Operating weight	kg	310	330	410	450	480

(1) condenser air in 35°C, evaporator water in/out 12/7°C

(2) evaporator air in 7°C, condenser water in/out 40/45°C

(3) at 1m in open field fan side

* compressor + fan

Model 0072								Model 0092								Model 0122							
Ta.	Tw	5	6	7	8	9	10	Ta.	Tw	5	6	7	8	9	10	Ta.	Tw	5	6	7	8	9	10
25,0	Pf	19,3	19,9	20,5	21,2	21,8	22,4	25,0	Pf	24,5	25,3	26,0	26,7	27,4	28,2	25,0	Pf	33,4	34,5	35,5	36,6	37,7	38,7
	Pa	4,6	4,6	4,6	4,7	4,7	4,7		Pa	6,7	6,7	6,8	6,9	7,0	7,0		Pa	7,5	7,6	7,6	7,7	7,8	7,8
	Pat	5,2	5,2	5,2	5,3	5,3	5,3		Pat	7,3	7,3	7,4	7,5	7,6	7,6		Pat	8,7	8,8	8,8	8,9	9,0	9,0
	Qev	3,3	3,4	3,5	3,6	3,8	3,9		Qev	4,2	4,3	4,5	4,6	4,7	4,8		Qev	5,8	5,9	6,1	6,3	6,5	6,7
	Δ_{Pev}	39	41	43	46	51	54		Δ_{Pev}	39	40	44	46	50		Δ_{Pev}	47	48	52	55	59	62	
30,0	Pf	18,2	18,8	19,4	20,0	20,6	21,2	30,0	Pf	23,1	23,8	24,5	25,2	25,9	26,6	30,0	Pf	31,7	32,7	33,7	34,8	35,8	36,8
	Pa	5,1	5,2	5,2	5,3	5,3	5,3		Pa	7,6	7,7	7,7	7,8	7,9	7,9		Pa	8,4	8,5	8,5	8,6	8,7	8,7
	Pat	5,7	5,8	5,8	5,9	5,9	5,9		Pat	8,2	8,3	8,3	8,4	8,5	8,5		Pat	9,6	9,7	9,7	9,8	9,9	9,9
	Qev	3,1	3,2	3,3	3,4	3,5	3,6		Qev	4,0	4,1	4,2	4,3	4,5	4,6		Qev	5,5	5,6	5,8	6,0	6,2	6,3
	Δ_{Pev}	34	36	39	41	43	46		Δ_{Pev}	35	37	39	40	44	46		Δ_{Pev}	42	44	47	50	53	55
32,0	Pf	17,8	18,3	18,9	19,5	20,1	20,7	32,0	Pf	22,5	23,2	23,9	24,6	25,3	25,9	32,0	Pf	31,0	32,0	33,0	34,0	35,0	36,0
	Pa	5,4	5,4	5,5	5,5	5,6	5,6		Pa	8,0	8,0	8,1	8,2	8,2	8,3		Pa	8,8	8,8	8,9	9,0	9,1	9,1
	Pat	6,0	6,0	6,1	6,1	6,2	6,2		Pat	8,6	8,6	8,7	8,8	8,8	8,9		Pat	10,0	10,0	10,1	10,2	10,3	10,3
	Qev	3,1	3,2	3,3	3,4	3,5	3,6		Qev	3,9	4,0	4,1	4,2	4,4	4,5		Qev	5,3	5,5	5,7	5,9	6,0	6,2
	Δ_{Pev}	34	36	39	41	43	46		Δ_{Pev}	33	32	37	39	42	44		Δ_{Pev}	39	42	45	48	50	53
35,0	Pf	17,1	17,6	18,2	18,8	19,3	19,9	35,0	Pf	21,7	22,3	23,0	23,7	24,3	25,0	35,0	Pf	29,9	30,9	31,9	32,8	33,8	34,7
	Pa	5,8	5,8	5,9	5,9	5,9	6,0		Pa	8,6	8,6	8,7	8,8	8,8	8,9		Pa	9,4	9,5	9,5	9,6	9,7	9,7
	Pat	6,4	6,4	6,5	6,5	6,5	6,6		Pat	9,2	9,2	9,3	9,4	9,4	9,5		Pat	10,6	10,7	10,7	10,8	10,9	10,9
	Qev	2,9	3,0	3,1	3,2	3,3	3,4		Qev	3,7	3,8	4,0	4,1	4,2	4,3		Qev	5,2	5,3	5,5	5,7	5,8	6,0
	Δ_{Pev}	30	32	34	36	39	41		Δ_{Pev}	30	32	35	37	39	40		Δ_{Pev}	38	39	42	45	47	50
40,0	Pf	15,9	16,4	17,0	17,5	18,0	18,6	40,0	Pf	20,2	20,8	21,5	22,1	22,7	23,4	40,0	Pf	28,1	29,0	29,9	30,8	31,7	32,6
	Pa	6,5	6,5	6,6	6,6	6,6	6,7		Pa	9,7	9,7	9,8	9,8	9,9	9,9		Pa	10,5	10,6	10,6	10,7	10,8	10,9
	Pat	7,1	7,1	7,2	7,2	7,2	7,3		Pat	10,3	10,3	10,4	10,4	10,5	10,5		Pat	11,7	11,8	11,8	11,9	12,0	12,1
	Qev	2,7	2,8	2,9	3,0	3,1	3,2		Qev	3,5	3,6	3,7	3,8	3,9	4,0		Qev	4,8	5,0	5,1	5,3	5,5	5,6
	Δ_{Pev}	26	28	30	32	34	36		Δ_{Pev}	27	28	30	32	33	35		Δ_{Pev}	32	35	36	39	42	44
43,0	Pf	15,2	15,7	16,2	16,7	17,3	17,8	43,0	Pf	19,3	19,9	20,5	21,1	21,7	22,4	43,0	Pf	26,9	27,7	28,6	29,5	30,3	31,2
	Pa	6,9	7,0	7,0	7,0	7,1	7,1		Pa	10,4	10,4	10,5	10,5	10,6	10,6		Pa	11,2	11,3	11,4	11,4	11,5	11,6
	Pat	7,5	7,6	7,6	7,6	7,7	7,7		Pat	11,0	11,0	11,1	11,1	11,2	11,2		Pat	12,4	12,5	12,6	12,6	12,7	12,8
	Qev	2,6	2,7	2,8	2,9	3,0	3,1		Qev	3,3	3,4	3,5	3,6	3,7	3,8		Qev	4,6	4,8	4,9	5,1	5,2	5,4
	Δ_{Pev}	24	26	28	30	32	34		Δ_{Pev}	24	25	27	28	30	32		Δ_{Pev}	29	32	33	36	38	40

Model 0152							Model 0182								
Ta.	Tw	5	6	7	8	9	10	Ta.	Tw	5	6	7	8	9	10
25,0	Pf	41,6	42,9	44,2	45,5	46,8	48,1	25,0	Pf	47,3	48,7	50,1	51,5	52,9	54,3
	Pa	9,5	9,6	9,7	9,8	9,9	10,0		Pa	11,3	11,4	11,5	11,7	11,8	11,9
	Pat	10,7	10,8	10,9	11,0	11,1	11,2		Pat	12,5	12,6	12,7	12,9	13,0	13,1
	Qev	7,2	7,4	7,6	7,8	8,1	8,3		Qev	8,1	8,4	8,6	8,9	9,1	9,4
	Δ_{Pev}	54	57	60	63	68	72		Δ_{Pev}	53	57	60	64	67	72
30,0	Pf	39,4	40,7	41,9	43,2	44,5	45,7	30,0	Pf	44,7	46,1	47,5	48,8	50,2	51,5
	Pa	10,7	10,8	10,9	11,0	11,1	11,2		Pa	12,6	12,7	12,9	13,0	13,1	13,2
	Pat	11,9	12,0	12,1	12,2	12,3	12,4		Pat	13,8	13,9	14,1	14,2	14,3	14,4
	Qev	6,8	7,0	7,2	7,4	7,7	7,9		Qev	7,7	7,9	8,2	8,4	8,6	8,9
	Δ_{Pev}	48	51	54	57	62	65		Δ_{Pev}	48	51	54	57	60	64
32,0	Pf	38,4	39,7	40,9	42,2	43,4	44,7	32,0	Pf	43,7	45,0	46,4	47,7	49,0	50,4
	Pa	11,2	11,3	11,4	11,5	11,6	11,7		Pa	13,1	13,3	13,4	13,5	13,7	13,8
	Pat	12,4	12,5	12,6	12,7	12,8	12,9		Pat	14,3	14,5	14,6	14,7	14,9	15,0
	Qev	6,6	6,8	7,0	7,3	7,5	7,7		Qev	7,5	7,8	8,0	8,2	8,4	8,7
	Δ_{Pev}	45	48	51	55	58	62		Δ_{Pev}	46	49	52	54	57	61
35,0	Pf	37,0	38,2	39,4	40,6	41,8	43,0	35,0	Pf	42,1	43,4	44,7	46,0	47,3	48,7
	Pa	12,0	12,1	12,2	12,3	12,4	12,5		Pa	14,0	14,1	14,3	14,4	14,6	14,7
	Pat	13,2	13,3	13,4	13,5	13,6	13,7		Pat	15,2	15,3	15,5	15,6	15,8	15,9
	Qev	6,4	6,6	6,8	7,0	7,2	7,4		Qev	7,2	7,5	7,7	7,9	8,2	8,4
	Δ_{Pev}	43	45	48	51	54	57		Δ_{Pev}	42	46	48	51	54	57
40,0	Pf	34,3	35,5	36,6	37,7	38,8	39,9	40,0	Pf	39,3	40,6	41,9	43,2	44,5	45,8
	Pa	13,5	13,6	13,7	13,8	13,9	14,0		Pa	15,5	15,7	15,8	15,9	16,1	16,2
	Pat	14,7	14,8	14,9	15,0	15,1	15,2		Pat	16,7	16,9	17,0	17,1	17,3	17,4
	Qev	5,9	6,1	6,3	6,5	6,7	6,9		Qev	6,8	7,0	7,2	7,4	7,7	7,9
	Δ_{Pev}	36	39	41	44	47	49		Δ_{Pev}	37	40	42	44	48	51
43,0	Pf	32,6	33,7	34,8	35,8	36,9	37,9	43,0	Pf	37,5	38,8	40,1	41,4	42,8	44,1
	Pa	14,5	14,6	14,7	14,8	14,9	14,9		Pa	16,5	16,6	16,8	16,9	17,1	17,2
	Pat	15,7	15,8	15,9	16,0	16,1	16,1		Pat	17,7	17,8	18,0	18,1	18,3	18,4
	Qev	5,6	5,8	6,0	6,2	6,4	6,5		Qev	6,5	6,7	6,9	7,1	7,4	7,6
	Δ_{Pev}	33	35	37	40	43	44		Δ_{Pev}	34	36	39	41	44	47

Ta: outside air temperature (°C)
 Pa: compressor power input (kW)
 Δ_{Pev} : evaporator pressure drop (kPa)
 Tw: evaporator water outlet temperature (°C)
 Pat: total power input (kW)
 Pf: cooling capacity (kW)
 Qev: evaporator water flow (m³/h)

Model 0072								Model 0092								Model 0122							
Ta.	Tw	5	6	7	8	9	10	Ta.	Tw	5	6	7	8	9	10	Ta.	Tw	5	6	7	8	9	10
25,0	Pf	18,3	18,9	19,5	20,1	20,7	21,3	25,0	Pf	23,3	24,0	24,7	25,4	26,1	26,7	25,0	Pf	31,7	32,8	33,8	34,8	35,8	36,8
	Pa	4,6	4,6	4,6	4,7	4,7	4,7		Pa	6,7	6,7	6,8	6,9	7,0	7,0		Pa	7,5	7,6	7,6	7,7	7,8	7,8
	Pat	5,2	5,2	5,2	5,3	5,3	5,3		Pat	7,3	7,3	7,4	7,5	7,6	7,6		Pat	8,7	8,8	8,8	8,9	9,0	9,0
	Qev	3,2	3,3	3,4	3,5	3,6	3,7		Qev	4,0	4,1	4,2	4,4	4,5	4,6		Qev	5,5	5,6	5,8	6,0	6,2	6,3
	ΔPev	35	38	40	42	45	47		ΔPev	35	37	39	43	45	47		ΔPev	43	44	47	51	54	56
30,0	Pf	17,3	17,9	18,4	19,0	19,5	20,1	30,0	Pf	22,0	22,6	23,3	23,9	24,6	25,2	30,0	Pf	30,1	31,1	32,1	33,0	34,0	35,0
	Pa	5,1	5,2	5,2	5,3	5,3	5,3		Pa	7,6	7,7	7,7	7,8	7,9	7,9		Pa	8,4	8,5	8,5	8,6	8,7	8,7
	Pat	5,7	5,8	5,8	5,9	5,9	5,9		Pat	8,2	8,3	8,3	8,4	8,5	8,5		Pat	9,6	9,7	9,7	9,8	9,9	9,9
	Qev	3,0	3,1	3,2	3,3	3,4	3,5		Qev	3,8	3,9	4,0	4,1	4,2	4,3		Qev	5,2	5,4	5,5	5,7	5,9	6,0
	ΔPev	31	33	35	38	40	42		ΔPev	32	34	35	37	39	41		ΔPev	38	41	43	46	49	51
32,0	Pf	16,9	17,4	18,0	18,5	19,1	19,6	32,0	Pf	21,4	22,1	22,7	23,4	24,0	24,6	32,0	Pf	29,5	30,4	31,4	32,3	33,2	34,2
	Pa	5,4	5,4	5,5	5,5	5,6	5,6		Pa	8,0	8,0	8,1	8,2	8,2	8,3		Pa	8,8	8,8	8,9	9,0	9,1	9,1
	Pat	6,0	6,0	6,1	6,1	6,2	6,2		Pat	8,6	8,6	8,7	8,8	8,8	8,9		Pat	10,0	10,0	10,1	10,2	10,3	10,3
	Qev	2,9	3,0	3,1	3,2	3,3	3,4		Qev	3,7	3,8	3,9	4,0	4,1	4,2		Qev	5,1	5,2	5,4	5,6	5,7	5,9
	ΔPev	29	31	33	35	38	40		ΔPev	30	32	34	35	37	39		ΔPev	37	38	41	44	46	49
35,0	Pf	16,2	16,8	17,3	17,8	18,4	18,9	35,0	Pf	20,6	21,2	21,8	22,5	23,1	23,7	35,0	Pf 2	8,4	29,4	30,3	31,2	32,1	33,0
	Pa	5,8	5,8	5,9	5,9	5,9	6,0		Pa	8,6	8,6	8,7	8,8	8,8	8,9		Pa	9,4	9,5	9,5	9,6	9,7	9,7
	Pat	6,4	6,4	6,5	6,5	6,5	6,6		Pat	9,2	9,2	9,3	9,4	9,4	9,5		Pat	10,6	10,7	10,7	10,8	10,9	10,9
	Qev	2,8	2,9	3,0	3,1	3,2	3,3		Qev	3,5	3,7	3,8	3,9	4,0	4,1		Qev	4,9	5,1	5,2	5,4	5,5	5,7
	ΔPev	27	29	31	33	35	38		ΔPev	27	30	32	34	35	37		ΔPev	34	37	38	41	43	46
40,0	Pf	15,1	15,6	16,1	16,6	17,1	17,6	40,0	Pf	19,2	19,8	20,4	21,0	21,6	22,2	40,0	Pf	26,6	27,5	28,4	29,2	30,1	30,9
	Pa	6,5	6,5	6,6	6,6	6,6	6,7		Pa	9,7	9,7	9,8	9,8	9,9	9,9		Pa	10,5	10,6	10,6	10,7	10,8	10,9
	Pat	7,1	7,1	7,2	7,2	7,2	7,3		Pat	10,3	10,3	10,4	10,4	10,5	10,5		Pat	11,7	11,8	11,8	11,9	12,0	12,1
	Qev	2,6	2,7	2,8	2,9	3,0	3,0		Qev	3,3	3,4	3,5	3,6	3,7	3,8		Qev	4,6	4,7	4,9	5,0	5,2	5,3
	ΔPev	23	25	27	29	31	31		ΔPev	24	26	27	29	30	32		ΔPev	30	31	34	35	38	39
43,0	Pf	14,4	14,9	15,4	15,9	16,4	16,9	43,0	Pf	18,3	19,8	20,5	21,1	21,6	22,3	43,0	Pf	25,5	26,4	27,2	28,0	28,8	29,6
	Pa	6,9	7,0	7,0	7,0	7,1	7,1		Pa	10,4	10,4	10,5	10,5	10,6	10,6		Pa	11,2	11,3	11,4	11,4	11,5	11,6
	Pat	7,5	7,6	7,6	7,6	7,7	7,7		Pat	11,0	11,0	11,1	11,1	11,2	11,2		Pat	12,4	12,5	12,6	12,6	12,7	12,8
	Qev	2,5	2,6	2,7	2,7	2,8	2,9		Qev	3,1	3,4	3,5	3,6	3,7	3,8		Qev	4,4	4,5	4,7	4,8	5,0	5,1
	ΔPev	22	23	25	27	29	29		ΔPev	21	26	27	29	30	32		ΔPev	27	28	31	32	35	37

Model 0152								Model 0182							
Ta.	Tw	5	6	7	8	9	10	Ta.	Tw	5	6	7	8	9	10
25,0	Pf	39,5	40,7	42,0	43,2	44,5	45,7	25,0	Pf	44,9	46,3	47,6	49,0	50,3	51,6
	Pa	9,5	9,6	9,7	9,8	9,9	10,0		Pa	11,3	11,4	11,5	11,7	11,8	11,9
	Pat	10,7	10,8	10,9	11,0	11,1	11,2		Pat	12,5	12,6	12,7	12,9	13,0	13,1
	Qev	6,8	7,0	7,2	7,4	7,7	7,9		Qev	7,7	8,0	8,2	8,4	8,7	8,9
	ΔPev	49	51	54	57	62	66		ΔPev	48	52	54	57	61	64
30,0	Pf	37,4	38,6	39,8	41,0	42,2	43,5	30,0	Pf	42,5	43,8	45,1	46,4	47,6	48,9
	Pa	10,7	10,8	10,9	11,0	11,1	11,2		Pa	12,6	12,7	12,9	13,0	13,1	13,2
	Pat	11,9	12,0	12,1	12,2	12,3	12,4		Pat	13,8	13,9	14,1	14,2	14,3	14,4
	Qev	6,4	6,6	6,9	7,1	7,3	7,5		Qev	7,3	7,5	7,8	8,0	8,2	8,4
	ΔPev	43	46	50	53	56	59		ΔPev	43	45	49	52	54	57
32,0	Pf	36,5	37,7	38,9	40,1	41,3	42,4	32,0	Pf	41,5	42,8	44,1	45,3	46,6	47,8
	Pa	11,2	11,3	11,4	11,5	11,6	11,7		Pa	13,1	13,3	13,4	13,5	13,7	13,8
	Pat	12,4	12,5	12,6	12,7	12,8	12,9		Pat	14,3	14,5	14,6	14,7	14,9	15,0
	Qev	6,3	6,5	6,7	6,9	7,1	7,3		Qev	7,1	7,4	7,6	7,8	8,0	8,2
	ΔPev	42	44	47	50	53	56		ΔPev	41	44	47	49	52	54
35,0	Pf	35,1	36,3	37,4	38,6	39,7	40,9	35,0	Pf	40,0	41,2	42,5	43,7	45,0	46,2
	Pa	12,0	12,1	12,2	12,3	12,4	12,5		Pa	14,0	14,1	14,3	14,4	14,6	14,7
	Pat	13,2	13,3	13,4	13,5	13,6	13,7		Pat	15,2	15,3	15,5	15,6	15,8	15,9
	Qev	6,0	6,2	6,4	6,6	6,8	7,0		Qev	6,9	7,1	7,3	7,5	7,7	8,0
	ΔPev	38	40	43	46	49	51		ΔPev	38	41	43	45	48	52
40,0	Pf	32,6	33,7	34,8	35,8	36,9	37,9	40,0	Pf	37,3	38,5	39,8	41,0	42,3	43,5
	Pa	13,5	13,6	13,7	13,8	13,9	14,0		Pa	15,5	15,7	15,8	15,9	16,1	16,2
	Pat	14,7	14,8	14,9	15,0	15,1	15,2		Pat	16,7	16,9	17,0	17,1	17,3	17,4
	Qev	5,6	5,8	6,0	6,2	6,4	6,5		Qev	6,4	6,6	6,8	7,1	7,3	7,5
	ΔPev	33	35	38	40	43	44		ΔPev	33	35	37	41	43	45
43,0	Pf	31,0	32,0	33,0	34,1	35,1	36,0	43,0	Pf	35,6	36,9	38,1	39,4	40,6	41,9
	Pa	14,5	14,6	14,7	14,8	14,9	14,9		Pa	16,5	16,6	16,8	16,9	17,1	17,2
	Pat	15,7	15,8	15,9	16,0	16,1	16,1		Pat	17,7	17,8	18,0	18,1	18,3	18,4
	Qev	5,3	5,5	5,7	5,9	6,0	6,2		Qev	6,1	6,3	6,6	6,8	7,0	7,2
	ΔPev	29	32	34	37	38	40		ΔPev	30	32	35	37	40	42

Ta: outside air temperature (°C)
 Pa: compressor power input (kW)
 ΔPev: evaporator pressure drop (kPa)
 Tw: evaporator water outlet temperature (°C)
 Pat: total power input (kW)
 Pf: cooling capacity (kW)
 Qev: evaporator water flow (m³/h)

Ta. U.R.87%	Model 0072					Ta. U.R.87%	Model 0092					Ta. U.R.87%	Model 0122				
	Tw	35	40	45	50		Tw	35	40	45	50		Tw	35	40	45	50
-5	Pt	15,3	15,3	15,3	-	-5	Pt	19,2	19,7	20,1	-	-5	Pt	25,8	25,9	25,9	-
	Pa	4,6	5,2	5,8	-		Pa	6,2	7,1	8,2	-		Pa	7,7	8,6	9,7	-
	Pat	5,2	5,8	6,4	-		Pat	6,8	7,7	8,8	-		Pat	8,9	9,8	10,9	-
	Qc	2,7	2,7	2,7	-		Qc	3,3	3,4	3,5	-		Qc	4,5	4,5	4,5	-
	ΔP_c	21	21	21	-		ΔP_c	20	22	23	-		ΔP_c	24	24	24	-
0	Pt	17,2	17,1	17,0	16,9	0	Pt	21,9	22,1	22,3	22,5	0	Pt	28,9	28,8	28,7	28,7
	Pa	4,6	5,2	5,9	6,6		Pa	6,2	7,1	8,1	9,3		Pa	7,8	8,7	9,8	11,0
	Pat	5,2	5,8	6,5	7,2		Pat	6,8	7,7	8,7	9,9		Pat	9,0	9,9	11,0	12,2
	Qc	3,0	3,0	3,0	3,0		Qc	3,8	3,8	3,9	3,9		Qc	5,0	5,0	5,0	5,0
	ΔP_c	26	26	26	26		ΔP_c	27	27	29	29		ΔP_c	29	29	29	29
7	Pt	20,7	20,4	20,2	19,9	7	Pt	26,2	26,1	26,1	26,1	7	Pt	34,5	34,2	33,9	33,6
	Pa	4,7	5,3	5,9	6,7		Pa	6,2	7,1	8,0	9,1		Pa	8,0	9,0	10,0	11,2
	Pat	5,3	5,9	6,5	7,3		Pat	6,8	7,7	8,6	9,7		Pat	9,2	10,2	11,2	12,4
	Qc	3,6	3,5	3,5	3,5		Qc	4,5	4,5	4,5	4,5		Qc	6,0	5,9	5,9	5,9
	ΔP_c	38	36	36	36		ΔP_c	38	38	38	38		ΔP_c	42	41	41	41
10	Pt	22,4	22,1	21,9	21,6	10	Pt	28,2	28,0	27,9	27,9	10	Pt	37,3	36,9	36,5	36,1
	Pa	4,7	5,3	6,0	6,7		Pa	6,2	7,1	8,0	9,1		Pa	8,1	9,1	10,2	11,3
	Pat	5,3	5,9	6,6	7,3		Pat	6,8	7,7	8,6	9,7		Pat	9,3	10,3	11,4	12,5
	Qc	3,9	3,8	3,8	3,8		Qc	4,9	4,9	4,9	4,9		Qc	6,5	6,4	6,4	6,3
	ΔP_c	45	42	42	42		ΔP_c	45	45	45	45		ΔP_c	50	48	48	47
15	Pt	25,8	25,4	25,1	24,7	15	Pt	31,8	31,6	31,4	31,3	15	Pt	42,6	42,0	41,4	40,8
	Pa	4,8	5,4	6,0	6,7		Pa	6,3	7,1	8,1	9,1		Pa	8,3	9,3	10,4	11,5
	Pat	5,4	6,0	6,6	7,3		Pat	6,9	7,7	8,7	9,7		Pat	9,5	10,5	11,6	12,7
	Qc	4,5	4,4	4,4	4,3		Qc	5,5	5,5	5,5	5,5		Qc	7,4	7,3	7,2	7,1
	ΔP_c	60	57	57	54		ΔP_c	57	57	57	57		ΔP_c	64	63	61	59

Ta. U.R.87%	Model 0152					Ta. U.R.87%	Model 0182				
	Tw	35	40	45	50		Tw	35	40	45	50
-5	Pt	32,3	32,2	32,2	-	-5	Pt	35,6	35,9	36,2	-
	Pa	9,9	11,2	12,6	-		Pa	10,9	12,4	14,1	-
	Pat	11,1	12,4	13,8	-		Pat	12,1	13,6	15,3	-
	Qc	5,6	5,6	5,6	-		Qc	6,2	6,2	6,3	-
	ΔP_c	27	27	27	-		ΔP_c	27	27	28	-
0	Pt	36,4	36,2	35,9	35,7	0	Pt	40,7	40,6	40,5	40,3
	Pa	9,9	11,2	12,6	14,2		Pa	11,1	12,5	14,1	15,9
	Pat	11,1	12,4	13,8	15,4		Pat	12,3	13,7	15,3	17,1
	Qc	6,3	6,3	6,3	6,2		Qc	7,1	7,1	7,0	7,0
	ΔP_c	35	35	35	34		ΔP_c	35	35	34	34
7	Pt	43,6	43,1	42,6	42,1	7	Pt	48,9	48,4	47,9	47,4
	Pa	10,1	11,4	12,8	14,4		Pa	11,3	12,7	14,2	15,8
	Pat	11,3	12,6	14,0	15,6		Pat	12,5	13,9	15,4	17,0
	Qc	7,6	7,5	7,4	7,3		Qc	8,5	8,4	8,3	8,3
	ΔP_c	51	49	48	47		ΔP_c	50	49	48	48
10	Pt	47,2	46,6	45,9	45,2	10	Pt	52,9	52,2	51,6	50,9
	Pa	10,2	11,5	12,9	14,5		Pa	11,5	12,8	14,3	15,8
	Pat	11,4	12,7	14,1	15,7		Pat	12,7	14,0	15,5	17,0
	Qc	8,2	8,1	8,0	7,9		Qc	9,2	9,1	9,0	8,9
	ΔP_c	59	58	56	55		ΔP_c	59	58	56	55
15	Pt	53,7	53,0	52,2	51,2	15	Pt	59,9	59,1	58,3	57,7
	Pa	10,5	11,8	13,2	14,7		Pa	11,8	13,1	14,5	16,0
	Pat	11,7	13,0	14,4	15,9		Pat	13,0	14,3	15,7	17,2
	Qc	9,3	9,2	9,1	8,9		Qc	10,4	10,3	10,2	10,1
	ΔP_c	76	74	73	69		ΔP_c	75	74	72	71

Ta: outside air temperature (°C)
Pa: compressor power input (kW)
 ΔP_c : evaporator pressure drop (kPa)
Tw: evaporator water outlet temperature (°C)
Pat: total power input (kW)
- conditions outside of operating limits
Pt: cooling capacity (kW)
Qc: condenser water flow (m³/h)

To operate the chiller, it is vital to respect the conditions given in the table:

RECOMMENDED
OPERATING
AREA

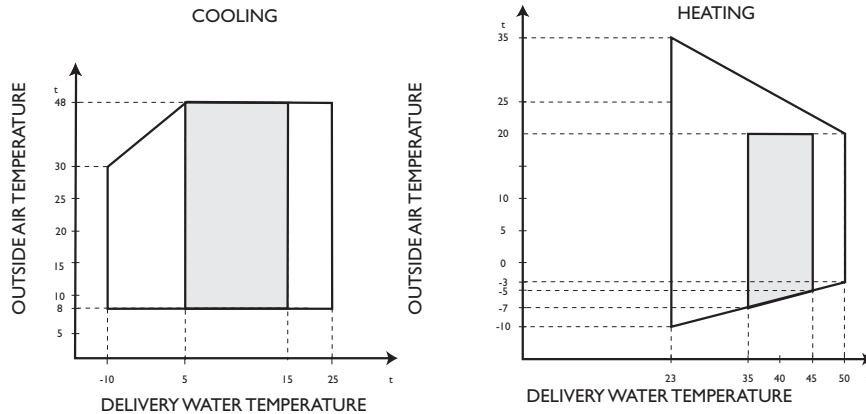

Thermal head min. max	3÷8
Water circuit pressure (bar)	1÷6
Max. storage temperature (°C)	63

ETHYLENE GLYCOL SOLUTIONS

Water and ethylene glycol solutions used as a thermal vector in the place of water reduce the performance of the unit. Multiply the performance figures by the values given in the following table.

Freezing point (°C)						
	0	-5	-10	-15	-20	-25
Percentage of ethylene glycol by weight						
	0	12%	20%	28%	35%	40%
cPf	1	0,985	0,98	0,974	0,97	0,965
cQ	1	1,02	1,04	1,075	1,11	1,14
cdp	1	1,07	1,11	1,18	1,22	1,24

cPf: cooling capacity correction factor

cQ: flow rate correction factor

cdp: pressure drop correction factor

FOULING FACTORS

The performance data given refer to conditions with clean evaporator plates (fouling factor=1). For different fouling factors, multiply the figures in the performance tables by the coefficient given in the following table.

Fouling factors (m ² °C/W)	Evaporator		
	fl	flkl	fxlfxl
4,4 × 10 ⁻⁵	-	-	-
0,86 × 10 ⁻⁴	0,96	0,99	0,99
1,72 × 10 ⁻⁴	0,93	0,98	0,98

fl capacity correction factor

flkl compressor power input correction factor

fxl total power input correction factor

SOUND PRESSURE LEVEL

Metres Model	1	5	10	15	20
	0072	68	62	48	44
0092	68	62	48	44	42
0122	71	65	51	47	45
0152	71	65	51	47	45
0182	71	65	51	47	45

Reference point: in open field at 1m from the surface of the unit on the coil side and 1m above the support surface.

MINIMUM WATER CONTENT

Model		0072	0092	0122	0152	0182
Minimum water content MICS	Litri	55	69	96	118	135
Minimum water content MICS-N	Litri	71	91	118	150	168

USEFUL PUMP HEAD CURVES (*)

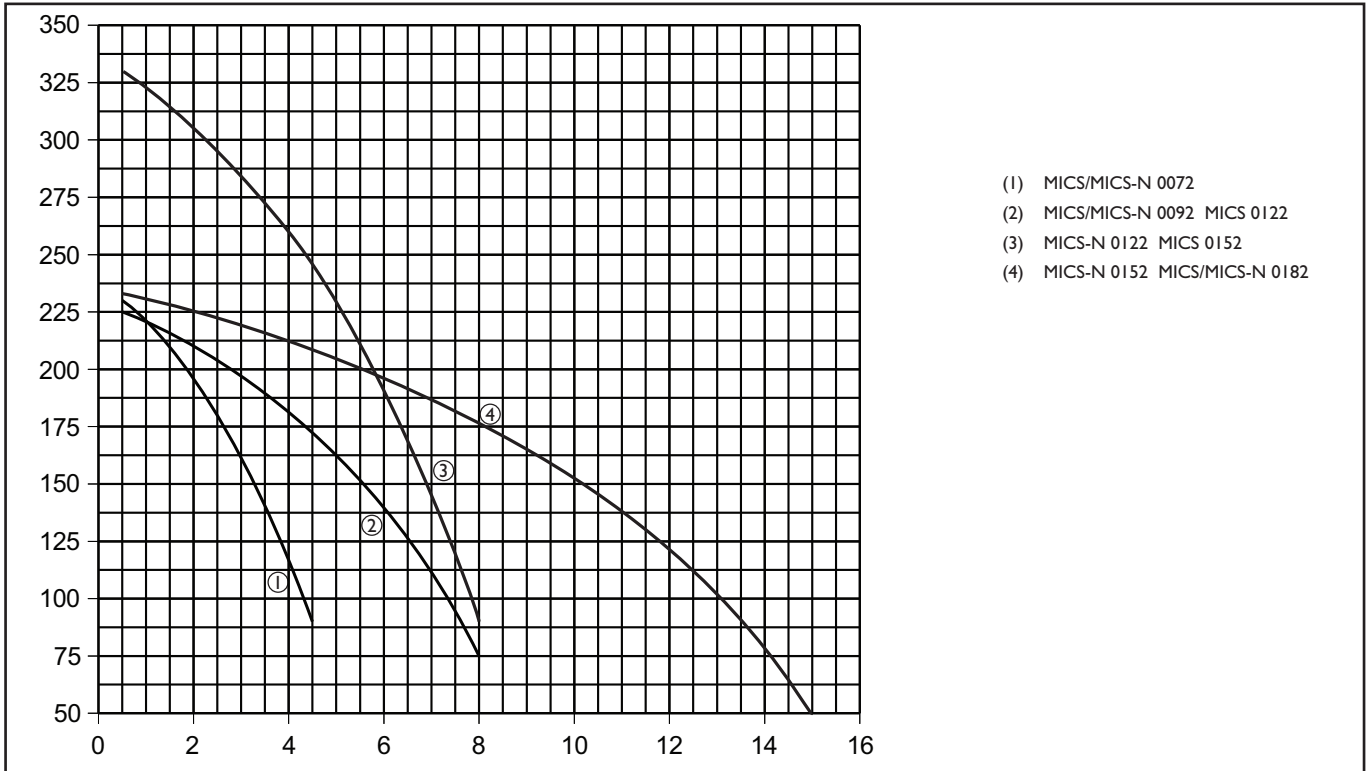

(*) To obtain the useful head of the installation, subtract the pressure drop of the plate heat exchanger

HEAT EXCHANGER PRESSURE DROP (WATER SIDE)

Model	Water flow	m³/h	3,0	3,1	4,0	5,5	6,8	7,7	8,0
		l/sec	0,83	0,86	1,11	1,53	1,89	2,14	2,22
0072	Pressure drop	kPa	32	34	-	-	-	-	-
0092		kPa	-	21	35	-	-	-	-
0122		kPa	-	14	22	42	64	82	-
0152		kPa	-	-	17	31	48	62	66
0182		kPa	-	-	-	24	37	48	52

Note: the values highlighted refer to the rated flow

evaporator water in/out IN/OUT

7/12° C

condenser air in

35°

PREPARING FOR FIRST START UP

or restarting after shutting down for long periods.

The chiller must be started up for the first time by the **Technical Service**.

Before starting up the chillers, make sure that:

- All safety conditions have been respected
- The chiller is adequately fixed to the surface it rests on
- Functional distances have been respected;
- Hydraulic connections have been carried out as indicated in the instruction manual
- The water circuit is filled and vented;
- The water circuit valves are open
- Electrical connections have been carried out correctly
- Voltage is within a tolerance of 10% of the rated voltage for the unit
- The unit is correctly earthed
- All electrical and hydraulic connections are tight and have been completed correctly.

! The unit must be started up for the first time with standard settings. Set point values may be modified only after testing has been completed. Before starting up, power the unit for at least two hours by switching QFI and QSI to ON and setting the control panel “HSW7” to OFF to allow the oil in the compressor sump to heat up.

INTERFACCIA UTENTE

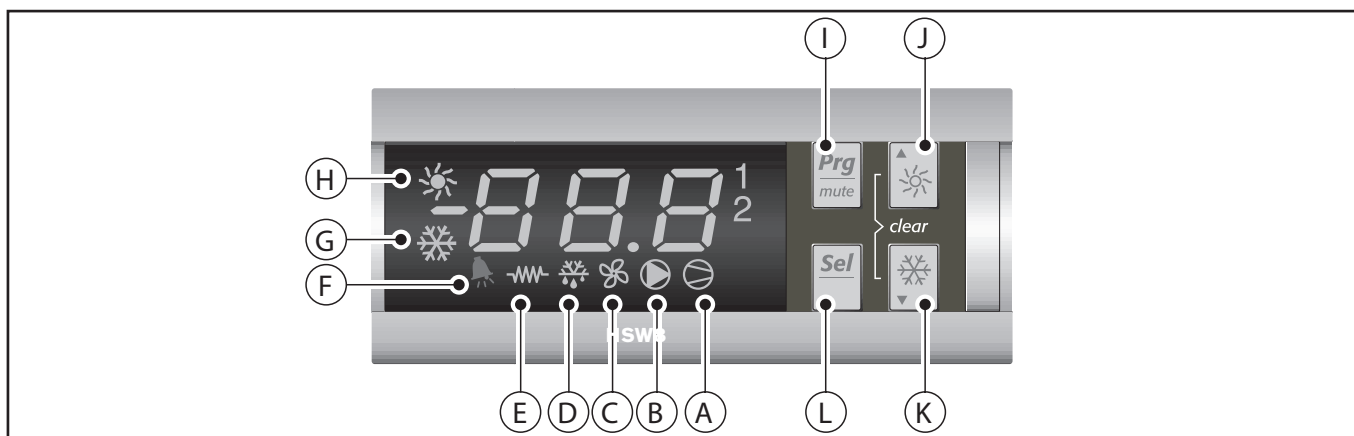

DISPLAY SYMBOLS

symbol	colour	Meaning with indicator light on	Meaning with indicator light blinking
1; 2	amber	compressor 1 or 2 on	richiesta di accensione
3; 4	amber	compressor 3 or 4 on	
A	amber	at least one compressor on	
B	amber	pump/fan for outflowing air on	
C	amber	condensation fan on	
D	amber	condensation fan	
E	amber	defrost active	
F	red	alarm active	
G	amber	chiller mode	
H	amber	heat pump mode	

ACTIVATING AND DEACTIVATING THE UNIT

- Put the on/off switch to ON

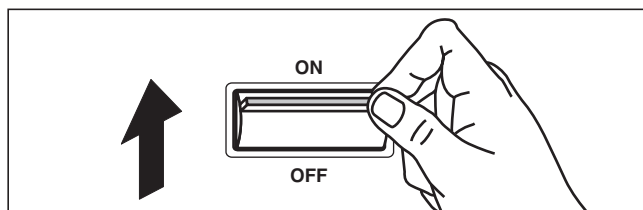

Cooling mode:

- To switch on the cooling mode, keep button K pressed for 5 sec. The mode of operation and the pump indicator lights come on.



One or both compressors may activate according to the temperature of the return flow of water.



Turning off:

To turn off the unit in the cooling mode, keep button K pressed for 5 sec.



⚠ At every change of season, make sure the operating conditions fall within the limits specified on page 16.

Check that the compressor current input is less than the maximum indicated in the table of technical data.

In three-phase models, check that the noise levels of the compressor are not abnormal. If this is the case, reverse one phase.

Make sure the voltage is within the established limits and that, for three phase units, the unbalance between the phases is less than 3%. Check that the cover is closed again following the setting procedure

- The temperature of the water returning from the system appears on the display:



Heating mode:

- To switch on the heating mode, keep button J pressed for 5 sec. The mode of operation and the pump indicator lights come on.



One or both compressors may activate according to the temperature of the return flow of water.



To turn off the unit in the heating mode, keep button J pressed for 5 sec.



SETTING THE SET POINTS

The factory Set Point settings are: cooling 12°C, heating 40°C.

To modify the set points, proceed as follows:

- Press button L for 5 sec. to access the main parameters window.



- Use button J or K to scroll to the “parameters R” sub-menu.



Press button L to access the “parameters R” submenu and use button J or K to scroll the accessible parameters of this menu:

LIST OF ACCESSIBLE PARAMETERS			
Parameter	Description	Unit of measure	Factory set point
r01	COOL set point	°C	12
r02	COOL C1/C2 ON/OFF differential	°C	3
r03	HEAT set point	°C	40
r04	HEAT C1/C2 ON/OFF differential	°C	3

Note: when setting the parameters the COMPRESSOR and HEATER LEDs will flash alternating with the DEFROST LED.

Press button L to change a parameter

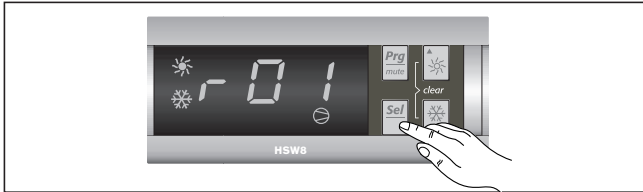

After having displayed the current value, use buttons J and K to change it.



Then press button I to exit without saving the change or button L to save the change.



Lastly press button I to return to the upper level menus or to exit from the configuration menu.

READING OF SENSOR VALUES

The following values may be displayed by pressing button J for 1 sec and scrolling with button J or K:



LIST OF ACCESSIBLE PARAMETERS		
Parameter	Description	Unit of measure
b01	water outlet temperature	°C
b02	water inlet temperature	°C
b04	high pressure value	
b09	low pressure value	

FAULT	CAUSE	REMEDY
Values display indication HPI	High pressure switch tripped	Check fault Reset the switch
Values display indication LPI	Low pressure switch tripped (automatic reset)	Check fault
Values display indication AI	Compressor thermal cut-out tripped (manual reset)	Check water outlet temperature Check water flow Check set point temperature
Values display indication E2	Water delivery sensor BT2 malfunction (automatic reset)	Check electrical connections Replace component
Values display indication E4	Coil sensor BT3 malfunction (automatic reset)	Check electrical connections Replace component
Values display indication E1	Water return sensor BT1 malfunction (automatic reset)	Check electrical connections Replace component
Values display indication FL	Differential pressure switch or flow switch tripped (automatic reset)	Check for inadequate water flow Check presence of air in water circuit

Set point in cooling

(factory setting) = 12°C, differential = 3°C.

With outlet water temperatures above 13.5°C, the 1st compressor activates, whereas with temperatures above 15°C, the 2nd compressor activates.

With water temperatures below 13.5°C, the 1st compressor switches off, whereas with temperatures below 12°C, the 2nd compressor switches off.

Set point in heating

(factory setting) = 40°C, differential = 3°C.

With outlet water temperatures above 38.5°C, the 1st compressor activates, whereas with temperatures above 37°C, the 2nd compressor activates.

With water temperatures below 38.5°C, the 1st compressor switches off, whereas with temperatures below 40°C, the 2nd compressor switches off.

In the event of a temporary power failure, when power returns, the mode set previously will be retained in the memory.

COMPRESSOR START UP DELAY

Two functions prevent the compressor from starting up too frequently.

- Minimum time since last shut-down 180 seconds.
- Minimum time since last start-up 300 seconds.
- Minimum time of operation for each compressor 60 sec.
- Minimum time for 2nd compressor ON from 1st compressor ON is 360 seconds.
- Minimum time for 2nd compressor OFF from 1st compressor OFF is 20 seconds.

PUMP

The electronic board has an output for control of the circulating pump, which starts up when the unit is switched on in either the cooling or heating mode and switches off 60 seconds after the unit has been switched off.

The water flow alarm functions (differential pressure switch and water flow switch) are activated after the first 20 seconds of pump operation, when the water flow is regular.

FAN SPEED CONTROL

For correct operation of the unit with different outside temperatures, the microprocessor controls the fan speed based on the pressure reading from the pressure transducer, thus enabling heat exchange to be increased and/or decreased, maintaining the condensing or evaporation pressures practically constant.

The fan functions independently of the compressor.

FROST PREVENTION ALARM

To prevent breakage of the plate-type heat exchanger due to freezing of the water inside it, the microprocessor provides for activation of the anti-frost heater if the temperature measured by the exchanger outlet temperature sensor is below +4°C and stopping of the compressors if the temperature is below +3°C.

This anti-frost temperature setting can be changed solely by an authorized service centre and only after having checked that there is antifreeze solution in the water circuit.

Activation of this alarm causes the compressor to stop and not the pump, which remains in operation.

To reset normal functions, the outlet water temperature must rise above +7°C; reset is manual.

WATER FLOW ALARM

The microprocessor provides for management of a water flow alarm controlled by a differential pressure switch fitted as standard on the appliance and a flow switch to be installed on the water delivery piping.

Tripping of this alarm shuts down the compressor but not the pump, which remains active.

After deactivating the chiller:

- Make sure the remote switch SAI (if present) is in the "OFF" position.
- Make sure the remote keyboard (if present) is set to "OFF".
- Position QFI and QSI on OFF
- Deactivate the indoor terminal units by placing the switch of each unit in the "OFF" position.
- Close the water valves



If there is a possibility that the outside temperature may drop below zero, there is the risk of freezing.

The water circuit **MUST BE EMPTIED AND CLOSED** or antifreeze must be added in the proportion recommended by the manufacturer.

Regular maintenance is fundamental to maintain the efficiency of the unit both in terms of operation and energy consumption.

The Technical Assistance Service maintenance plan must be observed, with an annual service which includes the following operations and checks:

- Filling of the water circuit
- Presence of air bubbles in the water circuit
- Efficiency of safety devices
- Power supply voltage
- Power input
- Tightness of electrical and hydraulic connections
- Condition of the compressor contactor

- Checking of operating pressure, superheating and sub-cooling
- Cleaning of finned coil
- Cleaning of fan grills
- Mesh filter cleaning (compulsory)



For units installed near the sea, the intervals between maintenance should be halved.

CHEMICAL WASHING

You are recommended to chemically wash the plate heat exchanger after every 3 years of operation. For instructions on how to carry out this operation, contact De'Longhi Spa.

REFRIGERANT GAS CONTENT

The chillers are filled R410A refrigerant gas and tested in the factory. In normal conditions, there should be no need for the Technical Assistance Service to intervene to check the refrigerant gas. However, over time, small leaks may develop at the joints leading to loss of refrigerant and draining of the circuit, causing the unit to function poorly. In this case, the leaks of refrigerant must be identified and repaired and the refrigerant circuit refilled. Proceed as follows:

- Empty and dry the entire refrigerant circuit using a vacuum pump connected to the low and high pressure tap until the vacuum reads about 10 Pa. Wait a couple of minutes and check that this value does not rise to more than 50 Pa.
- Connect the refrigerant gas cylinder or a filling cylinder to the low pressure line pressure gauge connection.
- Fill with the quantity of refrigerant gas indicated on the rating plate of the unit.
- Always check the superheating and subcooling values. In

the nominal operating conditions for the appliance, these should be between 4 and 8°C respectively.



In the event of partial leaks, the circuit must be completely emptied before being refilled.

The refrigerant must only be filled in the liquid state. **Operating conditions other than nominal** conditions may produce considerably different values.

Seal testing or identification of leaks must only be carried out using R410A refrigerant gas, checking with a suitable leak detector.



The refrigerant circuit must not be filled with a refrigerant other than R410A. The use of a refrigerant other than R410A may cause serious damage to the compressor.

Oxygen, acetylene or other flammable or poisonous gases must never be used in the refrigerant circuit as they may cause explosion.

Oils other than those indicated on page 12 must not be used. The use of different oils may cause serious damage to the compressor.

FAULT	CAUSE	REMEDY
<p>The chiller does not start up</p>	<p>No voltage</p>	<ul style="list-style-type: none"> - Check presence of voltage - Check safety systems upstream of the appliance
	<p>Mains switch in OFF position Remote switch (if present) in OFF position Control panel set to OFF Main unit switch in OFF position Compressor thermal solenoid switch OFF</p>	<p>Switch ON</p>
	<p>Supply voltage too low</p>	<p>Check power line</p>
	<p>Contactor coil faulty Electronic board faulty Start-up capacitor faulty (if present) Compressor faulty</p>	<p>Replace the component</p>
<p>Insufficient output</p>	<p>Insufficient refrigerant Sizing of unit Operation outside recommended limits</p>	<p>Check</p>
<p>Compressor noisy</p>	<p>Liquid returning to compressor Inadequate fixing</p>	<p>Check</p>
	<p>Reversed phase (three phase units only)</p>	<p>Reverse one phase</p>
<p>Noise and vibrations</p>	<p>Contact between metal bodies</p>	<p>Check</p>
	<p>Weak foundations</p>	<p>Repair</p>
	<p>Loose screws</p>	<p>Tighten screws</p>
<p>The compressor stops due to the activation of the protection devices</p>	<p>Excessive discharge pressure Low suction pressure Low voltage Electrical connections not sufficiently tight Operation outside permitted limits</p>	<p>Check</p>
	<p>Faulty operation of pressure switches</p>	<p>Replace the component</p>
	<p>Thermal cut-out tripped</p>	<p>Check supply voltage Check electrical insulation of windings</p>

FAULT	CAUSE	REMEDY
High discharge pressure (greater than 3,5 MPa)*	High external water temperature High water inlet temperature	Check fan operation
	Insufficient water flow Insufficient air flow	Check pump operation
	Faulty fan regulation	Check
	Air in water circuit	Vent air
	Excessive refrigerant charge	Check
Low discharge pressure (less than 1,8 MPa)*	Low outside air temperature Low water inlet temperature	Check
	Moisture in the refrigerant circuit (liquid indicator - moisture yellow)	Empty and refill
	Faulty fan regulation	Check
	Air in water circuit	Vent air
	Insufficient gas content	Check
High suction pressure (greater than 1,7 MPa)*	High outside air temperature High inflow water temperature Thermostatic expansion valve faulty or excessively open	Check
Low suction pressure (less than 0.62 MPa)*	Low utility water inlet temperature Low external water inlet temperature Thermostatic expansion valve faulty or blocked Clogged water filter Blocked plate heat exchanger	Check

*Values indicative only

For information on technical assistance and obtaining spare parts, contact

**FIXED AIR-CONDITIONING TECHNICAL SERVICE DEPARTMENT,
CLIMAVENETA HOME SYSTEM SRL**

via. L. Seitz, 47 - 31100 Treviso (ITALIA)

**www.climaveneta.it
info@climavenetahs.it**



Dé Longhi Group - Via L. Seitz, 47 - 31100 Treviso (Italia)